

TEREX DEMAG TC 2800-1

AUTOJEŘÁB

// **Tomáš Novotný**
AUTOJEŘÁBY DEMOLICE s.r.o.

TC 2800-1 | Truck Crane 600 t Lifting Capacity



TC 2800-1

TRUCK CRANE

- ▶ Great flexibility ensures considerable time and cost savings for transport and erection
- ▶ Large outrigger base gives outstanding lifting capacities and a maximum boom length of 192 m
- ▶ Significantly reduced transport units by comparison with the corresponding crawler crane model
- ▶ Basic machine roadable incl. all drums and A-frame within 12 tonne axle load limit
- ▶ Power-Kit for main boom
- ▶ Innovative Demag IC-1 crane control system with touchscreen

- ▶ Enorme Flexibilität bringt Zeit- und Kostenersparnis in puncto Transport und Aufbau
- ▶ Große Stützbasis ermöglicht enorme Tragfähigkeiten und eine maximale Auslegerlänge von 192 m
- ▶ Deutlich reduzierte Transporteinheiten im Vergleich zum entsprechenden Raupenkran
- ▶ Grundgerät inkl. allen Winden und A-Bock innerhalb der 12 t-Achslastbegrenzung verfahrbar
- ▶ Hauptausleger-Verstärkungs-Kit
- ▶ Innovative Kransteuerung Demag IC-1 mit Touchscreen

- ▶ Grande flexibilité assurant des économies financières et un gain de temps considérables en matière de transport et de montage
- ▶ Large base d'appui permettant d'excellentes capacités de levage et une longueur de flèche maximale de 192 m
- ▶ Unités de transport nettement réduites par comparaison avec le modèle sur chenilles correspondant
- ▶ Machine de base peut être déplacée sur route avec tous les treuils et le chevalet, dans les limites de poids à l'essieu de 12 tonnes
- ▶ Kit à fortifier de flèche principale
- ▶ Nouveau système de contrôle Demag IC-1 avec écran tactile

The technical data at a glance:

Max. lifting capacity:	600 t
Max. load moment:	7546 tm
Max. boom length:	96 + 96 m
Max. travel speed:	75 km/h
Carrier length:	17.95 m
Transport weight:	92 t
Drive / steering:	16 x 8 x 16
Max. gradeability:	43 %

Die technischen Daten auf einen Blick:

Max. Tragfähigkeit:	600 t
Max. Lastmoment:	7546 mt
Max. Auslegerlänge:	96 + 96 m
Max. Fahrgeschwindigkeit:	75 km/h
Fahrgestell-Länge:	17,95 m
Transportgewicht:	92 t
Antrieb / Lenkung:	16 x 8 x 16
Max. Steigfähigkeit:	43 %

Les caractéristiques techniques en un coup d'œil:

Capacité de levage maxi:	600 t
Couple de charge maxi:	7546 tm
Longueur de flèche maxi:	96 + 96 m
Vitesse sur route maxi:	75 km/h
Longueur du châssis:	17,95 m
Poids total roulant:	92 t
Entraînement / direction:	16 x 8 x 16
Capacité sur rampes:	43 %

Specifications · Technische Daten · Caractéristiques	
Specifications · Technische Daten · Caractéristiques	4
Superlift configurations · Superlift-Konfigurationen · Combinaisons Superlift	6
Specifications · Technische Daten · Caractéristiques	7
Boom combinations · Ausleger-Kombinationen · Combinaisons de flèche	10
Erection / lowering · Aufrichten / Ablegen · Monter / déposer	12

1

Main boom · Hauptausleger · Flèche principale	
Working ranges · Arbeitsbereiche · Portées (SH, SH / LH)	13
Lifting capacities · Tragfähigkeiten · Capacités de levage (SH, SH / LH)	14
Working ranges with Superlift · Arbeitsbereiche mit Superlift · Portées avec Superlift (SSL/HSSL, SSL/LSL)	16
Lifting capacities with Superlift · Tragfähigkeiten mit Superlift · Capacités de levage avec Superlift (SSL/HSSL, SSL/LSL)	17

2

Fixed fly jib · Starrer Hilfsausleger · Fléchette fixe	
Working ranges, 10° · Arbeitsbereiche, 10° · Portées, 10° (SH + LF2, SH/LH + LF2)	21
Lifting capacities · Tragfähigkeiten · Capacités de levage (SH + LF2, SH/LH + LF2)	22
Working ranges with SL, 10° · Arbeitsbereiche mit SL, 10° · Portées avec SL, 10° (SSL + LF2, SSL/LSL + LF2)	26
Lifting capacities with SL · Tragfähigkeiten mit SL · Capacités de levage avec SL (SSL + LF2, SSL/LSL + LF2)	27

3

Luffing fly jib · Wippbarer Hilfsausleger · Fléchette à volée variable	
Working ranges · Arbeitsbereiche · Portées (SW)	36
Lifting capacities · Tragfähigkeiten, Hauptausleger · Capacités de levage (SW)	37
Working ranges · Arbeitsbereiche · Portées (SWSL)	44
Lifting capacities with SL · Tragfähigkeiten mit SL · Capacités de levage avec SL (SWSL / SFSL 15° / HSWSL)	45

4

Fixed fly jib · Starrer Hilfsausleger · Fléchette fixe	
Working ranges with SL, 13° · Arbeitsbereiche mit SL, 13° · Portées avec SL, 13° (SFVL / LFVL)	58
Lifting capacities with SL · Tragfähigkeiten mit SL · Capacités de levage avec SL (SFVL / LFVL)	59

5

Technical description · Technische Beschreibung · Descriptif technique	
Carrier · Superstructure · Optional equipment	62
Boom configurations S and L	63
Unterwagen · Oberwagen · Zusatzausrüstung	64
Auslegervarianten S und L	65
Châssis · Partie supérieure · Equipements optionnels	66
Configurations de flèche S et L	67

6

TEREX DEMAG TC 2800-1

AUTOJEŘÁB

//Tomáš Novotný
AUTOJEŘÁBY DEMOLICE s.r.o.

SPECIFICATIONS · TECHNISCHE DATEN · CARACTÉRISTIQUES

WORKING SPEEDS (INFINITELY VARIABLE) · ARBEITSGESCHWINDIGKEITEN (STUFENLOS
REGELBAR) · VITESSES DE TRAVAIL (RÉGLABLES SANS PALIERS)

Mechanisms Antriebe Mécanismes	Rope \varnothing Seil- \varnothing \varnothing du câble	Speeds ¹⁾ Geschwindigkeiten ¹⁾ Vitesses ¹⁾	Single line pull ²⁾ Seilzug je Strang ²⁾ Effort sur brin simple ²⁾	Length of hoist rope Länge des Hubseils Longueur du câble de levage
Hoist I (H1) Hubwerk I (H1) Treuil de levage I (H1)	28 mm	max. 120 m / min	158 kN	900 m
Hoist II (H2) Hubwerk II (H2) Treuil de levage II (H2)	28 mm	max. 120 m / min	158 kN	900 m
Boom derricking (W2) Wippwerk Hauptausleger (W2) Variation de flèche (W2)	28 mm	max. 120 m / min		
Boom hoist (E) Einziehwerk (E) Relevage de flèche (E)	30 mm	max. 52 m / min		
Jib luffing (W1) Wippwerk Hilfsausleger (W1) Variation de volée (W1)	28 mm	max. 120 m / min		
Slewing (rpm) Drehwerk (U/min) Orientation (tr/mn)		0,7		

1) top layer · oberste Lage · couche supérieure

2) without reeving effect considered · Angabe ohne Wirkungsgrad der Einsicherung · sans effort de mouflage

BASIC CRANE DIMENSIONS · HAUPTABMESSUNGEN · DIMENSIONS DE LA GRUE DE BASE

Basic crane dimensions with standard Superlift attachment · Hauptabmessungen mit serienmäßiger Superlifteinrichtung ·
Dimensions de la grue de base avec Superlift de série

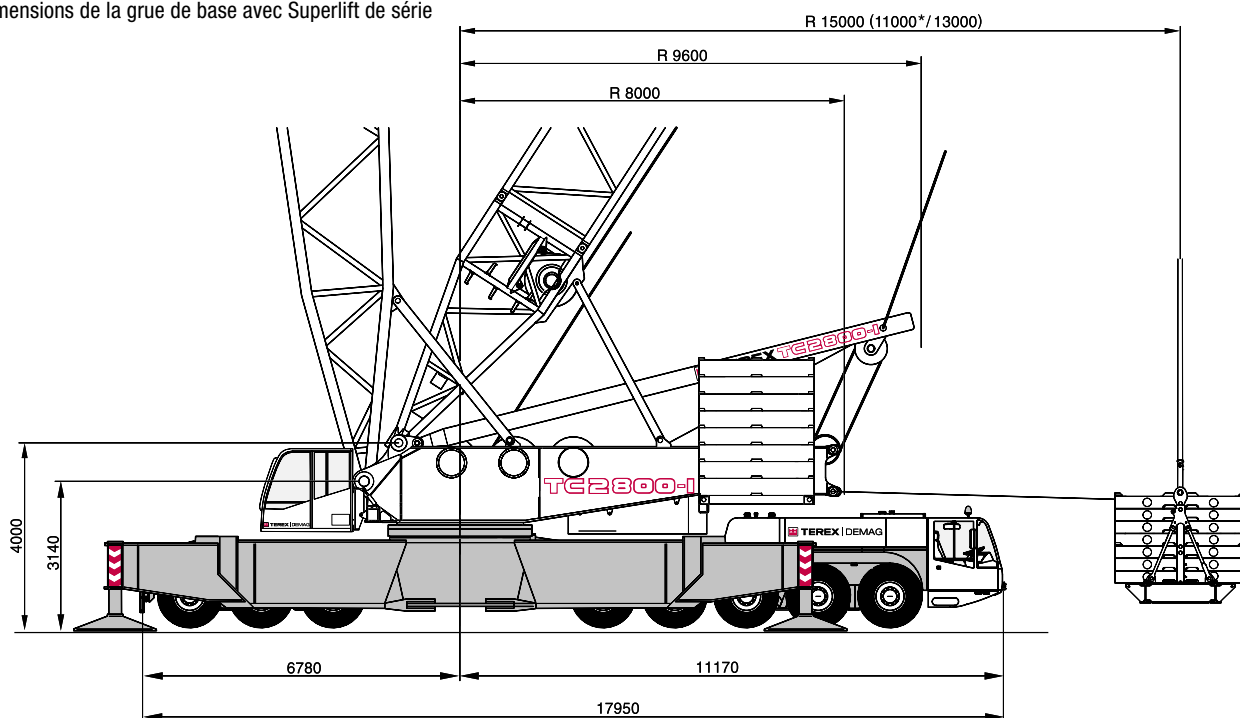

* Working range limited due to cabin and outriggers · Arbeitsbereich eingeschränkt durch Fahrerkabine und Stützen · Zone de fonction limité à la cabine et les stabilisateurs

TEREX DEMAG TC 2800-1

AUTOJEŘÁB

//Tomáš Novotný
AUTOJEŘÁBY DEMOLICE s.r.o.

SPECIFICATIONS · TECHNISCHE DATEN · CARACTÉRISTIQUES

HOOK BLOCKS · UNTERFLASCHEN · CROCHET-MOUFLE

Type Typ Type	Possible load Mögliche Traglast Charge possible	Number of sheaves Anzahl der Rollen Nombre de poulies	Number of lines Strangzahl Nombre de brins	Weight Gewicht Poids	„D“
2 x 300	600 t 247 t	2 x 11 11	2 x 22 17	10,4 t – 12,0 t 7,1 t – 7,9 t	5,00 m 5,40 m
2 x 200	400 t 196 t	2 x 7 7	2 x 14 13	8,2 t – 10,0 t 5,3 t – 6,2 t	5,00 m 5,40 m
160	160 t	5	11	3,3 t – 4,8 t	4,30 m
110	110 t	3	7	1,9 t – 3,6 t	4,30 m
50	50 t	1	3	2,8 t	4,00 m
16	16 t	—	1	0,9 t	3,00 m

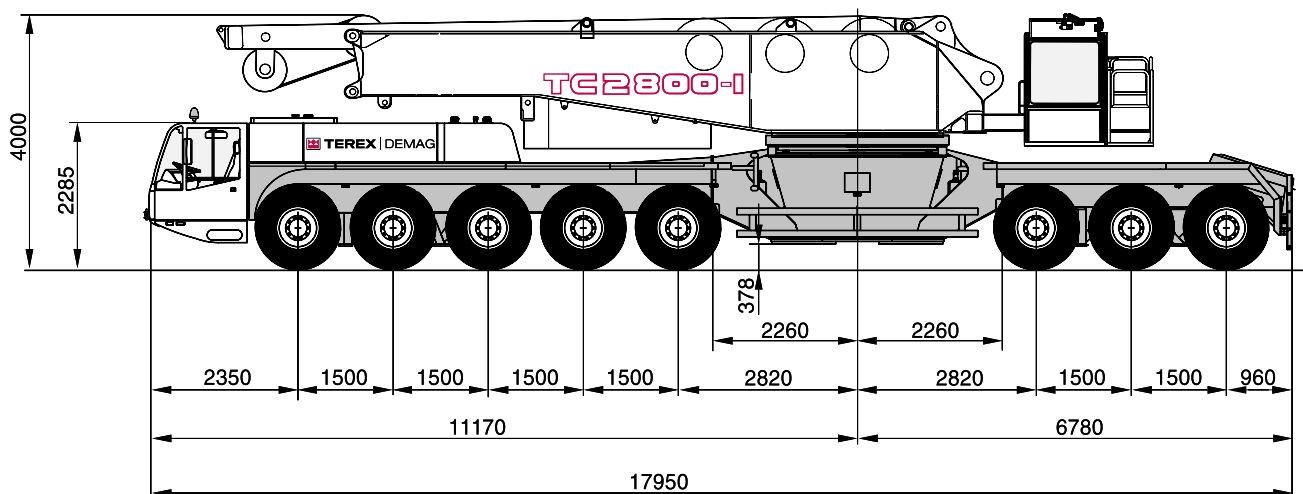
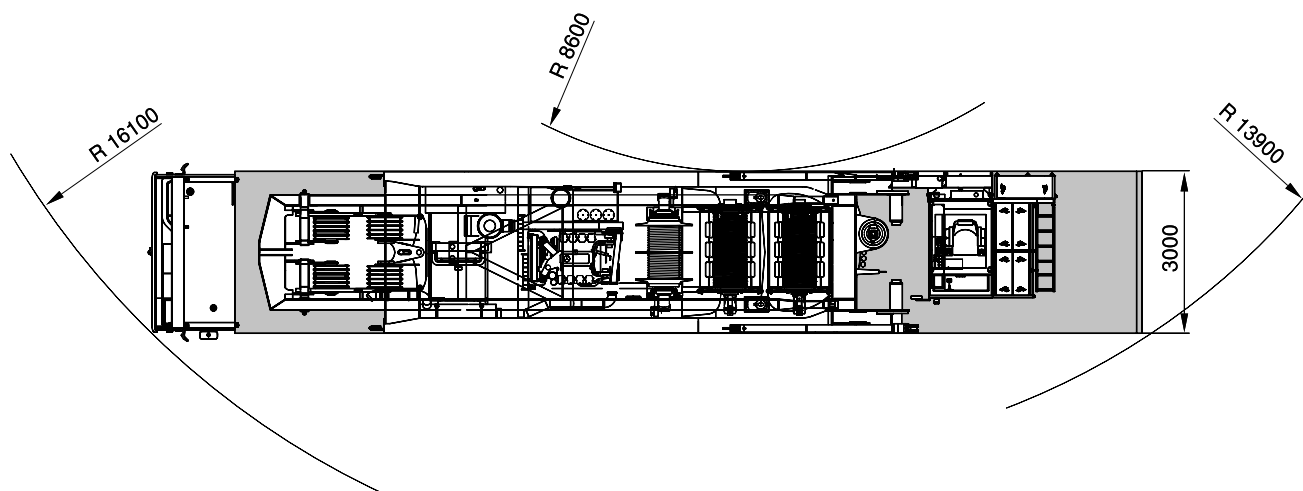

TEREX DEMAG TC 2800-1

AUTOJEŘÁB

//Tomáš Novotný
AUTOJEŘÁBY DEMOLICE s.r.o.

SUPERLIFT CONFIGURATIONS · SUPERLIFT-KONFIGURATIONEN ·
COMBINAISONS SUPERLIFT

STANDARD-SL

↔  11 m*, 13 m, 15 m

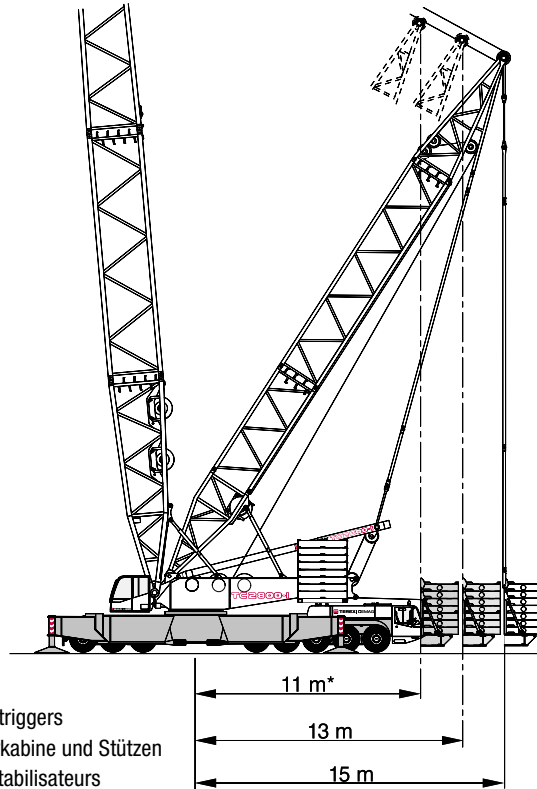

TELE-SL

↔  13-17 m

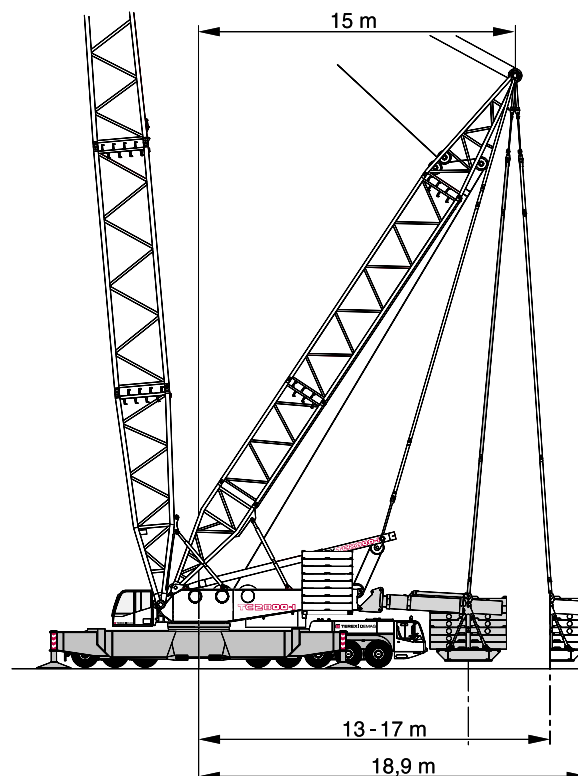

TEREX DEMAG TC 2800-1

AUTOJEŘÁB

//Tomáš Novotný
AUTOJEŘÁBY DEMOLICE s.r.o.

SPECIFICATIONS · TECHNISCHE DATEN · CARACTÉRISTIQUES

TRANSPORT · TRANSPORT · TRANSPORT

Tyres Bereifung Pneumatiques	14.00 R 25
Travel speed Fahrgeschwindigkeit Vitesse sur route	0 – 75 km/h
Gradeability Steigfähigkeit Capacité sur rampes	43 %
Fuel tank capacity for carrier Kraftstoffinhalt Unterwagen Réservoir du carburant pour châssis	970 l
Fuel tank capacity for superstructure Kraftstoffinhalt Oberwagen Réservoir du carburant pour partie supérieure	500 l

1

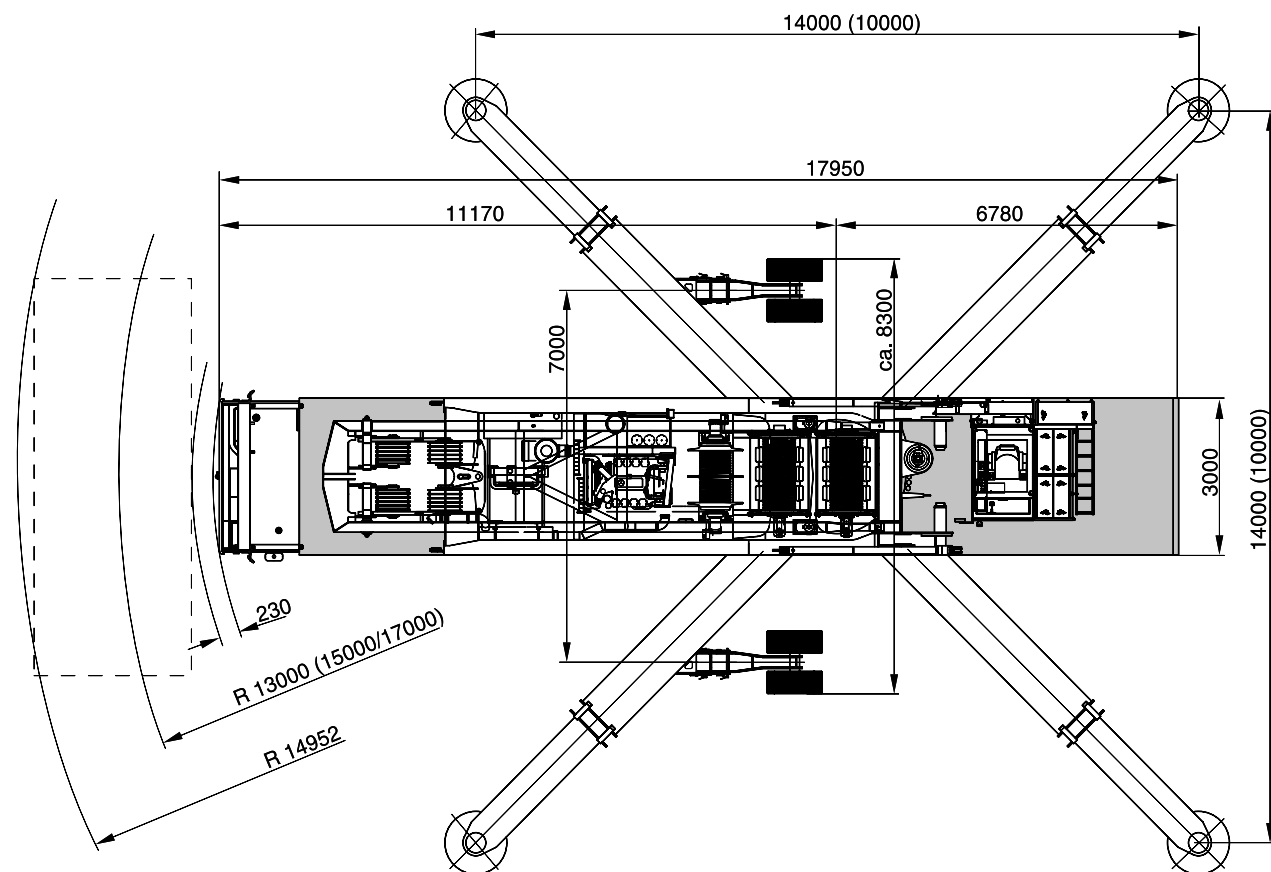

TEREX DEMAG TC 2800-1

AUTOJEŘÁB

//Tomáš Novotný
AUTOJEŘÁBY DEMOLICE s.r.o.

SPECIFICATIONS · TECHNISCHE DATEN · CARACTÉRISTIQUES

TRANSPORT · TRANSPORT · TRANSPORT

Total weight:
Gesamtgewicht:
Poids total:
92,0 t

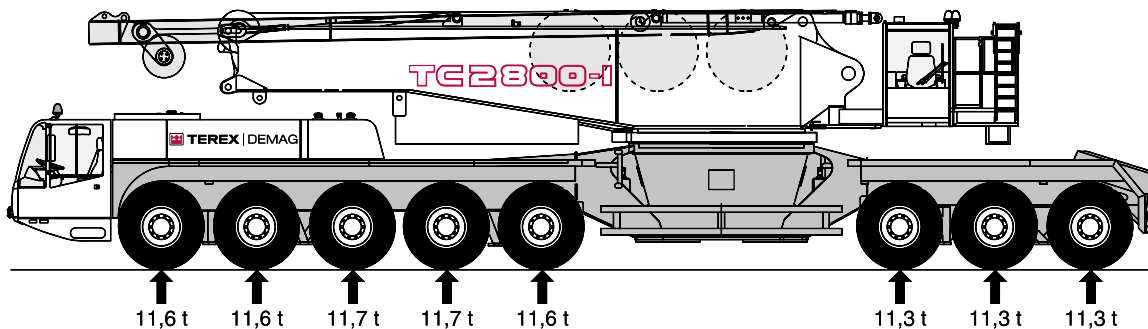

without winches H1+H2
ohne Winden H1+H2
sans tambours H1+H2

Total weight:
Gesamtgewicht:
Poids total:
80,8 t

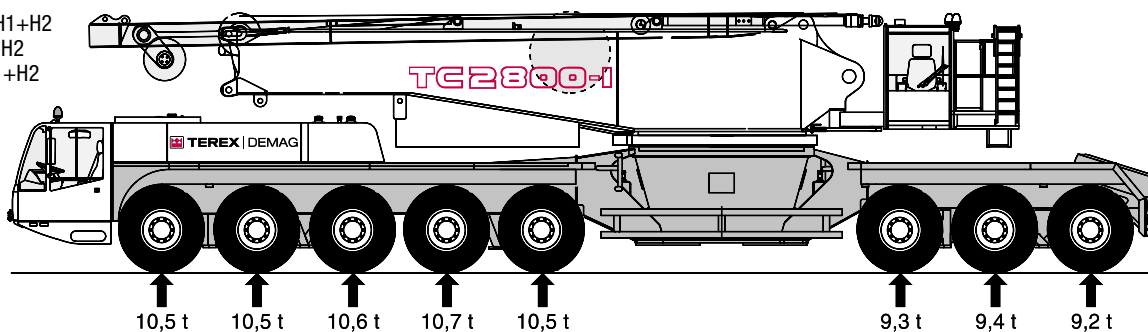

without winches H1+H2
without A-frame
ohne Winden H1+H2
ohne A-Bock
sans tambours H1+H2
sans chevalet

Total weight:
Gesamtgewicht:
Poids total:
77,0 t

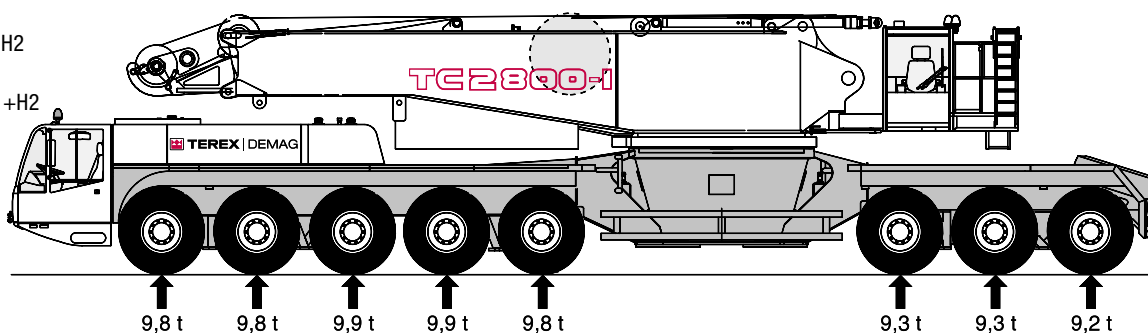

Total weight:
Gesamtgewicht:
Poids total:
36,6 t*

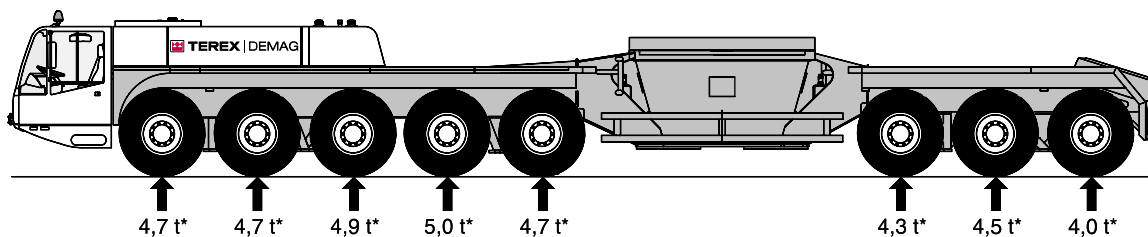

- * With quick-connection. Height with superstructure and quick connection 4.20 m.
- * Mit Schnellverbindung. Höhe mit Oberwagen und Schnellverbindung 4,20 m.
- * Avec connexion rapide. Hauteur avec partie supérieure et connexion rapide 4,20 m.

TEREX DEMAG TC 2800-1

AUTOJEŘÁB

//Tomáš Novotný
 AUTOJEŘÁBY DEMOLICE s.r.o.

SPECIFICATIONS · TECHNISCHE DATEN · CARACTÉRISTIQUES

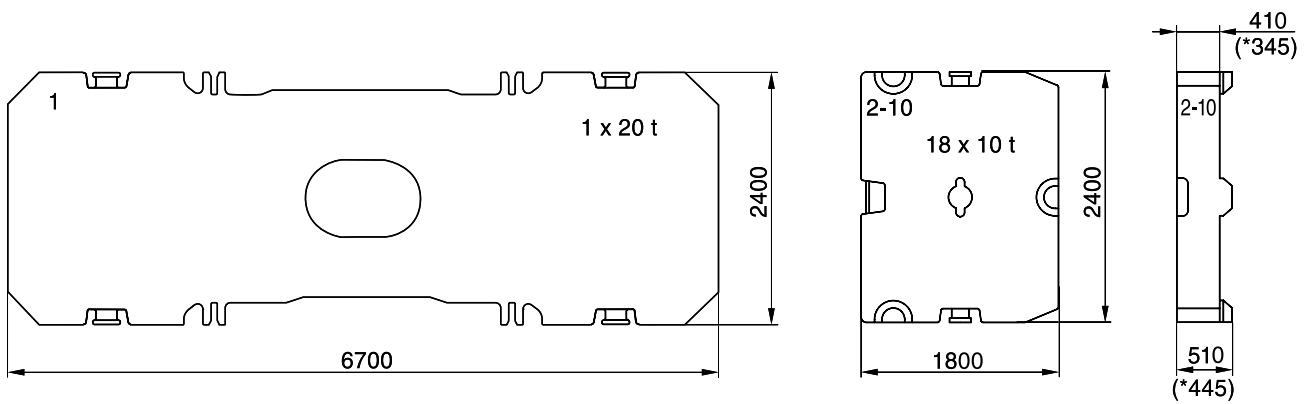
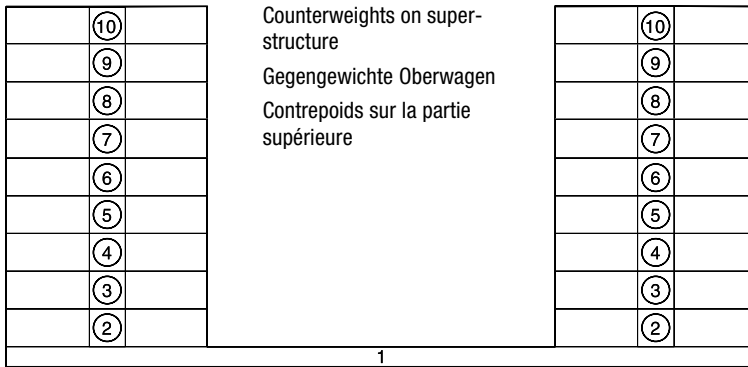

* optional · Option · option

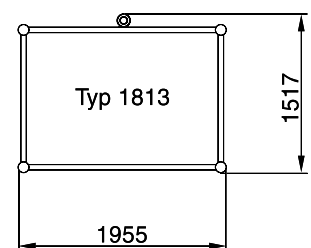
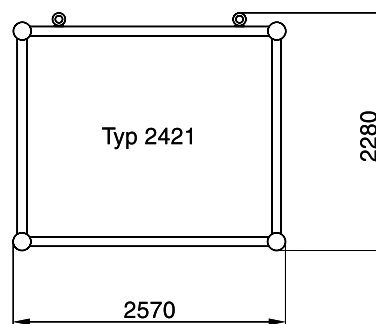
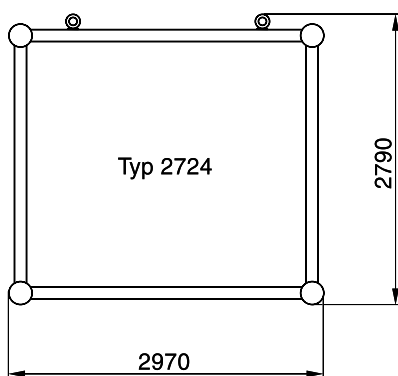
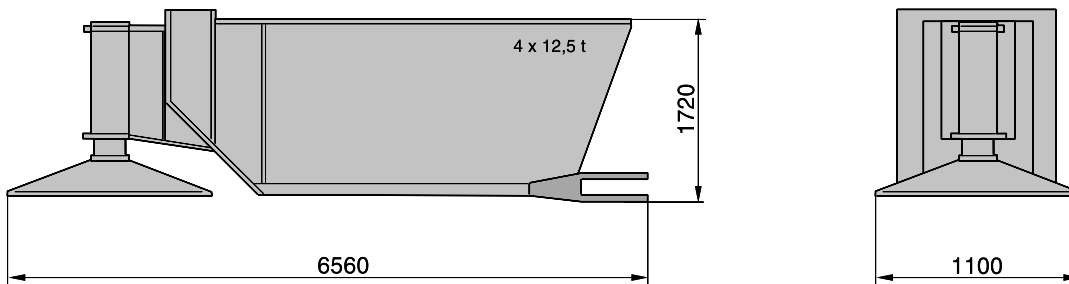

TEREX DEMAG TC 2800-1

AUTOJEŘÁB

//Tomáš Novotný
AUTOJEŘÁBY DEMOLICE s.r.o.

BOOM COMBINATIONS · AUSLEGER-KOMBINATIONEN · COMBINAISONS DE FLÈCHE

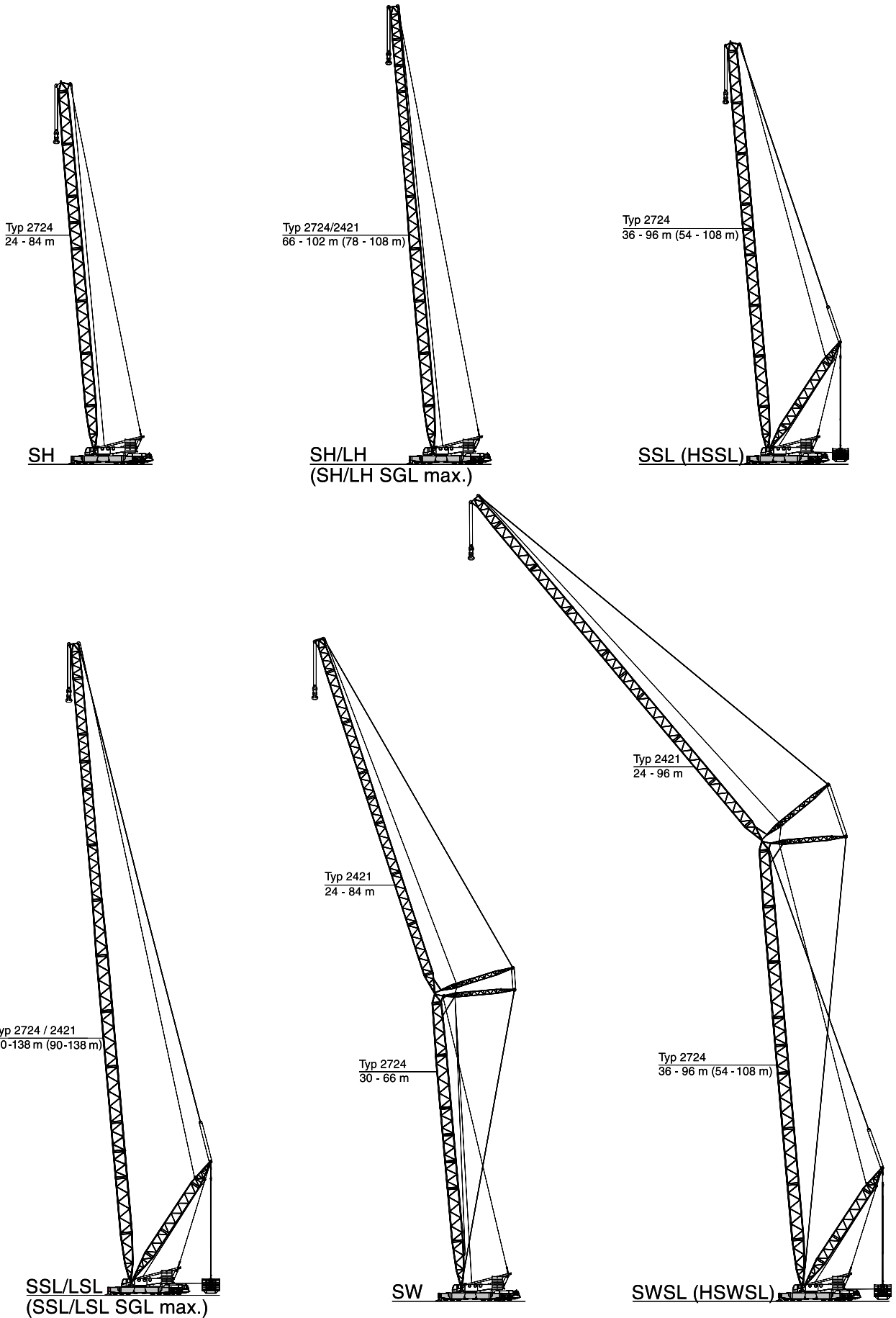

TEREX DEMAG TC 2800-1

AUTOJEŘÁB

//Tomáš Novotný
AUTOJEŘÁBY DEMOLICE s.r.o.

ERECTION / LOWERING OF THE TC 2800-1 BOOM SYSTEMS TO THE GROUND
AUFRICHTEN / ABLEGEN DER TC 2800-1 AUSLEGERSYSTEME
MONTÉE / PLACEMENT SUR SOL DES SYSTÈMES DE FLÈCHE DE LA TC 2800-1

160 - 200 t 11-15 m 14 m x 14 m

Boom combination Auslegervariante Combinaison de flèche	Fly jib Hilfsausleger Fléchette (m)	Main boom · Hauptausleger · Flèche principale																					
		m	24	30	36	42	48	54	60	66	72	78	84	90	96	102	108	114	120	126	132	138	
SH			X	X	X	X	X	X	X	X	X	X	X	X	X	X	X	X	X	X	X	X	X
SH/LH			-	-	-	-	-	-	-	X	X	X	X	X	X	(X)	-	-	-	-	-	-	-
SH/LH SGLmax.			-	-	-	-	-	-	-	-	X	X	X	X	X	(X)	-	-	-	-	-	-	-
SW	24		-	X	X	X	X	X	X	[X]	-	-	-	-	-	-	-	-	-	-	-	-	-
	30		-	X	X	X	X	X	X	[X]	-	-	-	-	-	-	-	-	-	-	-	-	-
	36		-	X	X	X	X	X	X	[X]	-	-	-	-	-	-	-	-	-	-	-	-	-
	42		-	X	X	X	X	X	X	[X]	-	-	-	-	-	-	-	-	-	-	-	-	-
	48		-	X	X	X	X	X	X	[X]	-	-	-	-	-	-	-	-	-	-	-	-	-
	54		-	X	X	X	X	X	X	[X]	-	-	-	-	-	-	-	-	-	-	-	-	-
	60		-	X	X	X	X	X	X	[X]	-	-	-	-	-	-	-	-	-	-	-	-	-
	66		-	X	X	X	X	X	X	[X]	-	-	-	-	-	-	-	-	-	-	-	-	-
	72		-	X	X	X	X	X	X	[X]	-	-	-	-	-	-	-	-	-	-	-	-	-
78		-	X	X	X	X	X	X	[X]	-	-	-	-	-	-	-	-	-	-	-	-	-	
84		-	X	X	X	X	X	X	[X]	-	-	-	-	-	-	-	-	-	-	-	-	-	
SH+LF2	12		-	X	X	X	X	X	X	X	X	X	X	X	X	(X)	-	-	-	-	-	-	-
SH/LH+LF2	12		-	-	-	-	-	-	-	X	X	X	X	X	X	(X)	-	-	-	-	-	-	-
SH/LH SGLmax. +LF2	12		-	-	-	-	-	-	-	-	X	X	X	X	[X]	[X]	-	-	-	-	-	-	-
SSL			-	-	0	0	0	0	0	0	0	0	5	25	45	-	-	-	-	-	-	-	-
HSSL			-	-	-	-	-	0	0	0	0	0	10	15	35	55	70	-	-	-	-	-	-
SSL/LSL			-	-	-	-	-	-	-	-	-	-	-	5	20	30	50	65	80	100	105	125	-
SSL /LSL SGLmax.			-	-	-	-	-	-	-	-	-	-	-	0	10	30	45	65	80	100	105	125	-
LFVL			-	-	-	0	0	0	0	5	25	50	65	90	115	-	-	-	-	-	-	-	-
SFVL			-	-	-	0	0	0	10	20	45	85	85	110	140	-	-	-	-	-	-	-	-
SWSL / SFSL	24		-	-	0	0	0	0	5	30	50	65	90	115	145	-	-	-	-	-	-	-	-
	30		-	-	0	0	0	0	5	25	55	80	95	125	155	-	-	-	-	-	-	-	-
	36		-	-	0	0	0	0	0	25	55	80	110	130	160	-	-	-	-	-	-	-	-
	42		-	-	0	0	0	0	0	20	50	80	105	135	165	-	-	-	-	-	-	-	-
	48		-	-	0	0	0	0	0	15	45	70	100	135	165	-	-	-	-	-	-	-	-
	54		-	-	0	0	0	0	0	5	30	65	100	130	165	-	-	-	-	-	-	-	-
	60		-	-	0	0	0	0	0	5	30	55	90	125	160	-	-	-	-	-	-	-	-
	66		-	-	0	0	0	0	0	10	35	55	90	110	150	-	-	-	-	-	-	-	-
	72		-	-	0	0	0	0	0	15	40	60	85	110	140	-	-	-	-	-	-	-	-
78		-	-	0	0	0	0	0	20	40	65	90	115	145	-	-	-	-	-	-	-	-	
84		-	-	0	0	0	0	0	20	45	70	95	120	150	-	-	-	-	-	-	-	-	
90		-	-	0	0	0	0	5	25	50	75	100	125	155	-	-	-	-	-	-	-	-	
96		-	-	0	0	0	0	5	30	55	75	105	130	160	-	-	-	-	-	-	-	-	
SSL+LF2	12		-	-	0	0	0	0	0	0	15	35	55	80	-	-	-	-	-	-	-	-	-
HSSL+LF2	12		-	-	-	-	-	0	0	0	0	0	10	30	50	70	-	-	-	-	-	-	-
SSL/LSL+LF2	12		-	-	-	-	-	-	-	-	-	-	-	45	60	75	95	115	135	155	185	195	-
SSL /LSL SGLmax. +LF2	12		-	-	-	-	-	-	-	-	0	0	5	20	40	65	90	110	130	160	190	-	-

Remarks · Bemerkungen · Remarques

X no limitations · ohne Einschränkungen · sans restrictions

(X) erecting to the rear · Aufrichten über die Hinterkante · montée vers l'arrière

[X] with assist crane · mit Hilfskran · avec grue auxiliaire

Values for LF with 10° jib offset; values may differ for other offsets · Werte für LF mit 10° Vorneigung; für andere Vorneigungen ergeben sich geringfügige Abweichungen · Valeurs LF avec inclinaison 10 degrés, pour d'autres inclinaisons de petites différences sont possibles.

All Superlift combinations can be erected or lowered to the ground without assisting equipment. The stated numbers represent the necessary SL-counterweight in [t]. · Alle Varianten mit Superlift können ohne Zusatzausrüstung aufgerichtet bzw. abgelegt werden. Die angegebenen Zahlenwerte entsprechen dem notwendigen SL-Ballast in [t]. · Montée et dépose sur sol de toutes les combinaisons avec SL sans équipement additionnel. Les valeurs indiquées correspondent au balast superlift [en to.] nécessaire.

TEREX DEMAG TC 2800-1

AUTOJEŘÁB

//Tomáš Novotný
AUTOJEŘÁBY DEMOLICE s.r.o.

SH, SH/LH WORKING RANGES · ARBEITSBEREICHE ·
PORTÉES

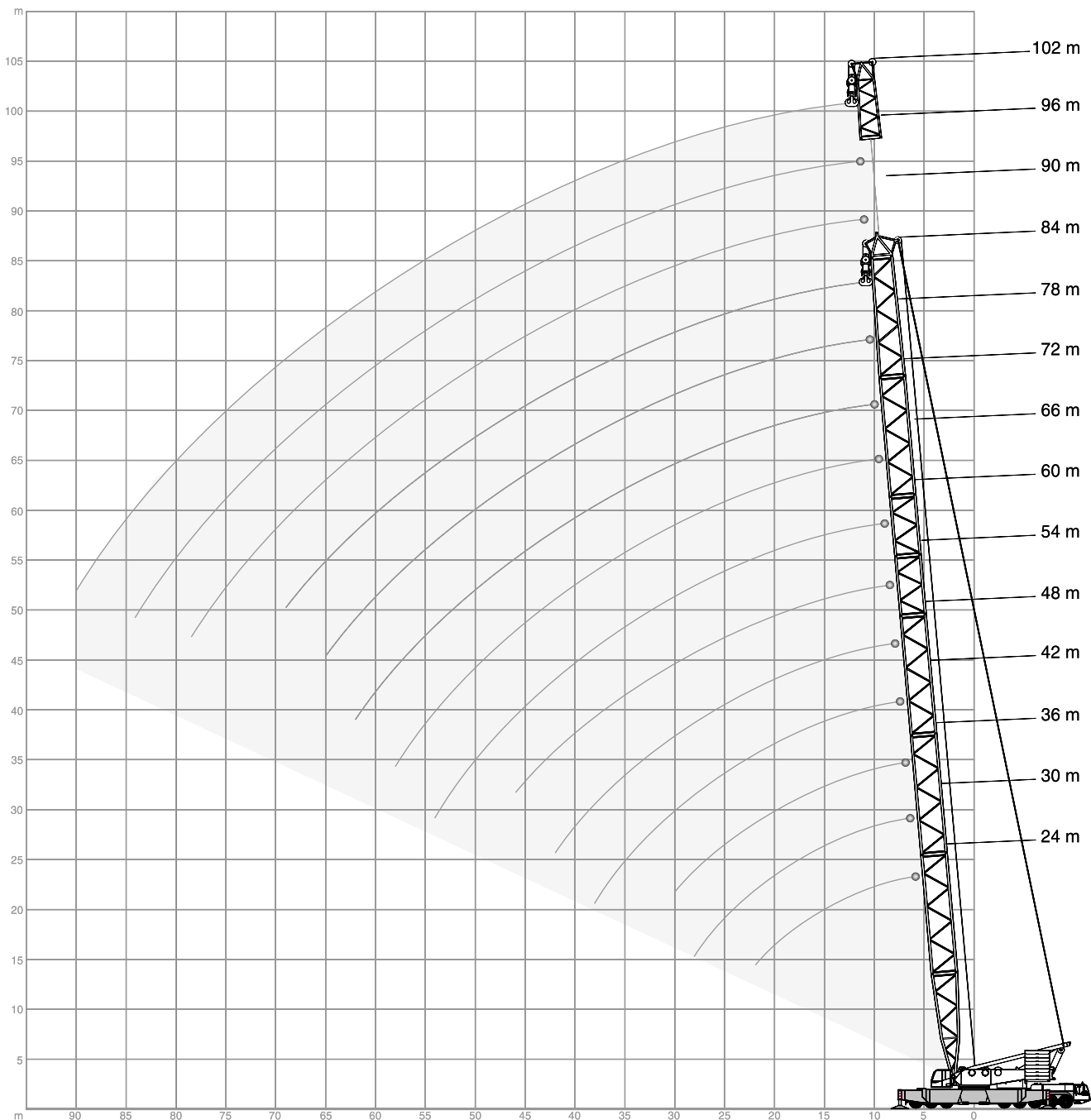

TEREX DEMAG TC 2800-1

AUTOJEŘÁB

//Tomáš Novotný
AUTOJEŘÁBY DEMOLICE s.r.o.

SH LIFTING CAPACITIES · TRAGFÄHIGKEITEN ·
CAPACITÉS DE LEVAGE

		14 m x 14 m											360°		DIN/ISO	
		24,0 m	30,0 m	36,0 m	42,0 m	48,0 m	54,0 m	60,0 m	66,0 m	72,0 m	78,0 m	84,0 m				
		t	t	t	t	t	t	t	t	t	t	t				
6	600,0	-	-	-	-	-	-	-	-	-	-	-	6	6		
7	552,0	549,0	545,0	-	-	-	-	-	-	-	-	-	7	7		
8	508,0	505,0	501,0	498,0	495,0	-	-	-	-	-	-	-	8	8		
9	461,0	457,0	454,0	451,0	449,0	447,0	415,0	-	-	-	-	-	9	9		
10	414,0	411,0	408,0	405,0	403,0	401,0	393,0	343,0	301,0	-	-	-	10	10		
12	337,0	334,0	332,0	329,0	327,0	325,0	324,0	315,0	278,0	256,0	212,0	-	12	12		
14	284,0	281,0	278,0	276,0	274,0	272,0	270,0	269,0	262,0	215,0	210,0	-	14	14		
16	245,0	242,0	239,0	237,0	234,0	232,0	231,0	229,0	228,0	200,0	177,0	-	16	16		
18	214,0	210,0	207,0	204,0	201,0	199,0	198,0	196,0	195,0	185,0	164,0	-	18	18		
20	187,0	186,0	181,0	178,0	176,0	174,0	172,0	170,0	169,0	166,0	152,0	-	20	20		
22	161,0	159,0	157,0	155,0	154,0	153,0	152,0	150,0	148,0	147,0	142,0	-	22	22		
24	-	139,0	137,0	135,0	133,0	133,0	132,0	131,0	130,0	130,0	127,0	-	24	24		
26	-	123,0	121,0	119,0	117,0	116,0	115,0	114,0	114,0	113,0	111,0	-	26	26		
28	-	110,0	108,0	106,0	104,0	103,0	102,0	101,0	100,0	99,5	98,0	-	28	28		
30	-	-	97,0	95,0	93,5	92,5	91,5	90,5	89,5	88,5	87,0	-	30	30		
34	-	-	-	78,5	76,5	75,5	74,5	73,5	72,5	71,5	70,0	-	34	34		
38	-	-	-	66,5	64,5	63,0	62,0	60,5	59,5	59,0	57,0	-	38	38		
42	-	-	-	-	55,5	53,5	52,5	51,0	50,0	49,2	47,4	-	42	42		
46	-	-	-	-	-	46,6	45,0	43,7	42,5	41,2	39,2	-	46	46		
50	-	-	-	-	-	-	39,1	37,5	36,0	34,7	32,6	-	50	50		
54	-	-	-	-	-	-	34,2	32,4	30,7	29,3	27,2	-	54	54		
58	-	-	-	-	-	-	-	28,2	26,3	24,8	22,7	-	58	58		
62	-	-	-	-	-	-	-	-	22,7	21,1	18,9	-	62	62		
66	-	-	-	-	-	-	-	-	-	18,0	15,7	-	66	66		
70	-	-	-	-	-	-	-	-	-	15,5	13,0	-	70	70		
74	-	-	-	-	-	-	-	-	-	-	10,8	-	74	74		
78	-	-	-	-	-	-	-	-	-	-	-	-	78	78		

		14 m x 14 m											360°		DIN/ISO	
		24,0 m	30,0 m	36,0 m	42,0 m	48,0 m	54,0 m	60,0 m	66,0 m	72,0 m	78,0 m	84,0 m				
		t	t	t	t	t	t	t	t	t	t	t				
6	600,0	-	-	-	-	-	-	-	-	-	-	-	6	6		
7	549,0	545,0	542,0	-	-	-	-	-	-	-	-	-	7	7		
8	496,0	493,0	490,0	487,0	484,0	-	-	-	-	-	-	-	8	8		
9	440,0	437,0	434,0	431,0	429,0	427,0	415,0	-	-	-	-	-	9	9		
10	391,0	388,0	385,0	382,0	380,0	378,0	377,0	343,0	301,0	-	-	-	10	10		
12	318,0	316,0	313,0	310,0	308,0	306,0	305,0	290,0	276,0	256,0	212,0	-	12	12		
14	268,0	265,0	262,0	260,0	258,0	256,0	247,0	237,0	227,0	215,0	208,0	-	14	14		
16	231,0	228,0	225,0	223,0	220,0	215,0	207,0	199,0	191,0	184,0	177,0	-	16	16		
18	189,0	187,0	186,0	184,0	183,0	183,0	177,0	170,0	164,0	158,0	152,0	-	18	18		
20	158,0	156,0	155,0	153,0	152,0	151,0	150,0	148,0	143,0	138,0	133,0	-	20	20		
22	135,0	133,0	132,0	130,0	129,0	128,0	127,0	126,0	126,0	122,0	118,0	-	22	22		
24	-	116,0	114,0	112,0	111,0	110,0	109,0	108,0	108,0	107,0	105,0	-	24	24		
26	-	102,0	100,0	98,5	97,0	96,0	95,5	94,5	93,5	93,0	91,5	-	26	26		
28	-	92,0	89,5	87,5	86,0	85,0	84,0	83,0	82,0	81,5	80,0	-	28	28		
30	-	-	80,5	78,5	76,5	75,5	74,5	73,5	73,0	72,0	70,5	-	30	30		
34	-	-	-	64,5	62,5	61,0	60,0	59,0	58,0	57,0	55,5	-	34	34		
38	-	-	-	54,0	52,0	50,5	49,6	48,5	47,5	46,6	44,6	-	38	38		
42	-	-	-	-	44,6	42,9	41,5	40,2	38,9	37,7	35,7	-	42	42		
46	-	-	-	-	-	36,7	34,9	33,4	32,0	30,8	28,7	-	46	46		
50	-	-	-	-	-	-	29,7	28,0	26,5	25,2	23,1	-	50	50		
54	-	-	-	-	-	-	25,5	23,7	22,0	20,6	18,5	-	54	54		
58	-	-	-	-	-	-	-	20,2	18,3	16,8	14,6	-	58	58		
62	-	-	-	-	-	-	-	-	15,3	13,7	11,4	-	62	62		
66	-	-	-	-	-	-	-	-	-	11,1	8,8	-	66	66		
70	-	-	-	-	-	-	-	-	-	9,0	6,6	-	70	70		

TEREX DEMAG TC 2800-1

AUTOJEŘÁB

//Tomáš Novotný
AUTOJEŘÁBY DEMOLICE s.r.o.

SH/LH LIFTING CAPACITIES · TRAGFÄHIGKEITEN ·
CAPACITÉS DE LEVAGE

		14 m x 14 m						360°			DIN/ISO		
m	t	66 m		72 m			78 m			84 m			
		SH/LH		SH/LH		SH/LH		SH/LH		SH/LH		SH/LH	
		160 t	200 t	160 t	200 t	160 t	200 t	160 t	200 t	160 t	200 t		
		SH/LH	SH/LH SGLmax.	SH/LH	SH/LH SGLmax.	SH/LH	SH/LH SGLmax.	SH/LH	SH/LH SGLmax.	SH/LH	SH/LH SGLmax.		
9	t	298,0	298,0	-	-	-	-	-	-	-	-	-	
10	t	298,0	298,0	-	268,0	268,0	-	202,0	202,0	222,0	-	-	-
11	t	290,5	290,5	-	268,0	268,0	-	202,0	202,0	222,0	-	-	215,0
12	t	283,0	283,0	-	268,0	268,0	-	202,0	202,0	222,0	169,0	169,0	215,0
14	t	236,0	236,0	-	220,0	220,0	-	178,0	178,0	193,0	150,0	150,0	204,0
16	t	202,0	209,0	-	193,0	193,0	-	158,0	158,0	167,0	133,0	133,0	184,0
18	t	174,0	184,0	-	168,0	170,0	-	140,0	140,0	145,0	119,0	119,0	166,0
20	t	152,0	162,0	-	148,0	150,0	-	125,0	125,0	127,0	107,0	107,0	149,0
22	t	132,0	145,0	-	131,0	134,0	-	112,0	112,0	112,0	96,0	96,0	134,0
24	t	114,0	134,0	-	114,0	123,0	-	102,0	102,0	101,0	87,0	87,0	120,0
26	t	100,0	120,0	-	100,0	114,0	-	95,0	95,0	95,0	80,0	80,0	107,0
28	t	89,0	107,0	-	89,0	105,0	-	88,0	88,0	89,5	73,0	73,0	99,5
30	t	79,5	96,5	-	79,5	96,0	-	79,0	81,5	84,0	67,5	67,5	94,0
34	t	65,0	79,0	-	64,5	79,0	-	64,5	69,5	72,5	58,0	58,0	76,5
38	t	54,0	66,5	-	54,0	66,0	-	53,5	60,0	61,5	49,4	49,4	63,5
42	t	46,0	57,0	-	45,6	56,5	-	45,2	51,0	50,0	41,5	41,5	54,0
46	t	39,4	49,3	-	39,0	48,8	-	38,6	45,0	41,2	35,0	35,0	46,1
50	t	34,1	43,0	-	33,6	42,0	-	33,1	39,0	37,3	31,0	31,0	39,8
54	t	29,7	38,0	-	29,0	37,0	-	28,4	34,0	33,4	27,0	27,0	34,3
58	t	25,9	33,8	-	25,2	33,0	-	24,5	30,0	29,5	23,4	25,0	29,6
62	t	-	-	-	21,9	29,0	-	21,2	26,0	25,6	20,0	22,0	25,6
66	t	-	-	-	-	-	-	18,4	22,0	21,7	17,2	19,0	22,3
70	t	-	-	-	-	-	-	16,0	18,0	17,8	14,7	16,0	19,4
74	t	-	-	-	-	-	-	-	-	-	12,0	12,0	16,9
75	t	-	-	-	-	-	-	-	-	-	-	-	16,3

m	t	90 m		96 m			102 m						
		SH/LH		SH/LH		SH/LH		SH/LH		SH/LH			
		160 t	200 t	160 t	200 t	160 t	200 t	160 t	200 t				
		SH/LH	SH/LH SGLmax.	SH/LH	SH/LH SGLmax.	SH/LH	SH/LH SGLmax.	SH/LH	SH/LH SGLmax.				
12	t	154,0	154,0	202,0	137,0	137,0	159,0	-	-	-	-	-	-
13	t	154,0	154,0	197,0	137,0	137,0	159,0	-	-	145,0	-	-	-
14	t	154,0	154,0	192,0	137,0	137,0	159,0	108,0	108,0	145,0	-	-	-
16	t	142,0	142,0	172,0	127,0	127,0	150,0	103,0	103,0	140,0	-	-	-
18	t	131,0	131,0	154,0	118,0	118,0	140,0	98,5	98,5	130,0	-	-	-
20	t	123,0	123,0	138,0	110,0	110,0	131,0	93,5	93,5	120,0	-	-	-
22	t	115,0	115,0	123,0	104,0	104,0	122,0	89,0	89,0	111,0	-	-	-
24	t	108,0	109,0	111,0	98,0	98,0	112,0	84,5	84,5	102,0	-	-	-
26	t	97,5	103,0	100,0	93,0	93,0	101,0	80,0	80,0	94,0	-	-	-
28	t	87,5	97,0	90,5	86,0	89,0	92,5	75,5	75,5	86,0	-	-	-
30	t	78,0	92,0	85,0	77,5	84,0	83,5	71,5	71,5	78,0	-	-	-
34	t	63,0	77,0	75,5	62,5	76,0	68,0	62,5	64,0	66,5	-	-	-
38	t	52,0	64,5	62,5	51,5	63,0	55,5	51,0	57,5	60,0	-	-	-
42	t	43,8	54,5	52,5	43,3	54,0	45,6	42,9	51,5	51,0	-	-	-
46	t	37,1	47,0	44,9	36,5	46,4	38,5	36,0	45,6	43,2	-	-	-
50	t	31,4	40,6	38,4	30,6	40,0	34,1	30,1	39,6	36,3	-	-	-
54	t	26,6	35,3	32,8	25,8	34,5	32,0	25,3	34,0	30,6	-	-	-
58	t	22,6	30,6	28,0	21,8	29,8	27,3	21,2	29,3	25,9	-	-	-
62	t	19,2	26,6	24,1	18,4	25,8	23,2	17,8	25,2	21,8	-	-	-
66	t	16,3	23,2	20,6	15,5	22,4	19,8	14,8	21,8	18,3	-	-	-
70	t	13,8	20,3	17,7	12,9	19,4	16,8	12,3	18,6	15,3	-	-	-
74	t	11,7	17,8	15,1	10,8	16,9	14,2	10,1	15,5	12,7	-	-	-
78	t	9,8	15,5	12,9	8,8	14,6	11,9	8,1	12,7	10,4	-	-	-
80	t	-	-	11,9	8,0	13,6	10,9	7,2	11,5	9,3	-	-	-
82	t	-	-	-	7,2	12,6	10,0	6,4	10,4	8,3	-	-	-
85	t	-	-	-	-	-	8,6	5,2	8,9	6,9	-	-	-
86	t	-	-	-	-	-	-	4,9	8,4	6,5	-	-	-
87	t	-	-	-	-	-	-	-	8,0	6,1	-	-	-
90	t	-	-	-	-	-	-	-	6,8	5,0	-	-	-

Remarks · Bemerkungen · Remarques

For SH/LH SGLmax. a boom power-kit is required · Für SH/LH SGLmax. ist ein Ausleger-Verstärkungs-Kit erforderlich ·
Un kit à fortifier de flèche principale est nécessaire pour SH/LH SGLmax.

TEREX DEMAG TC 2800-1

AUTOJEŘÁB

//Tomáš Novotný
AUTOJEŘÁBY DEMOLICE s.r.o.

SSL / HSSL, SSL / LSL WORKING RANGES · ARBEITSBEREICHE ·
PORTÉES

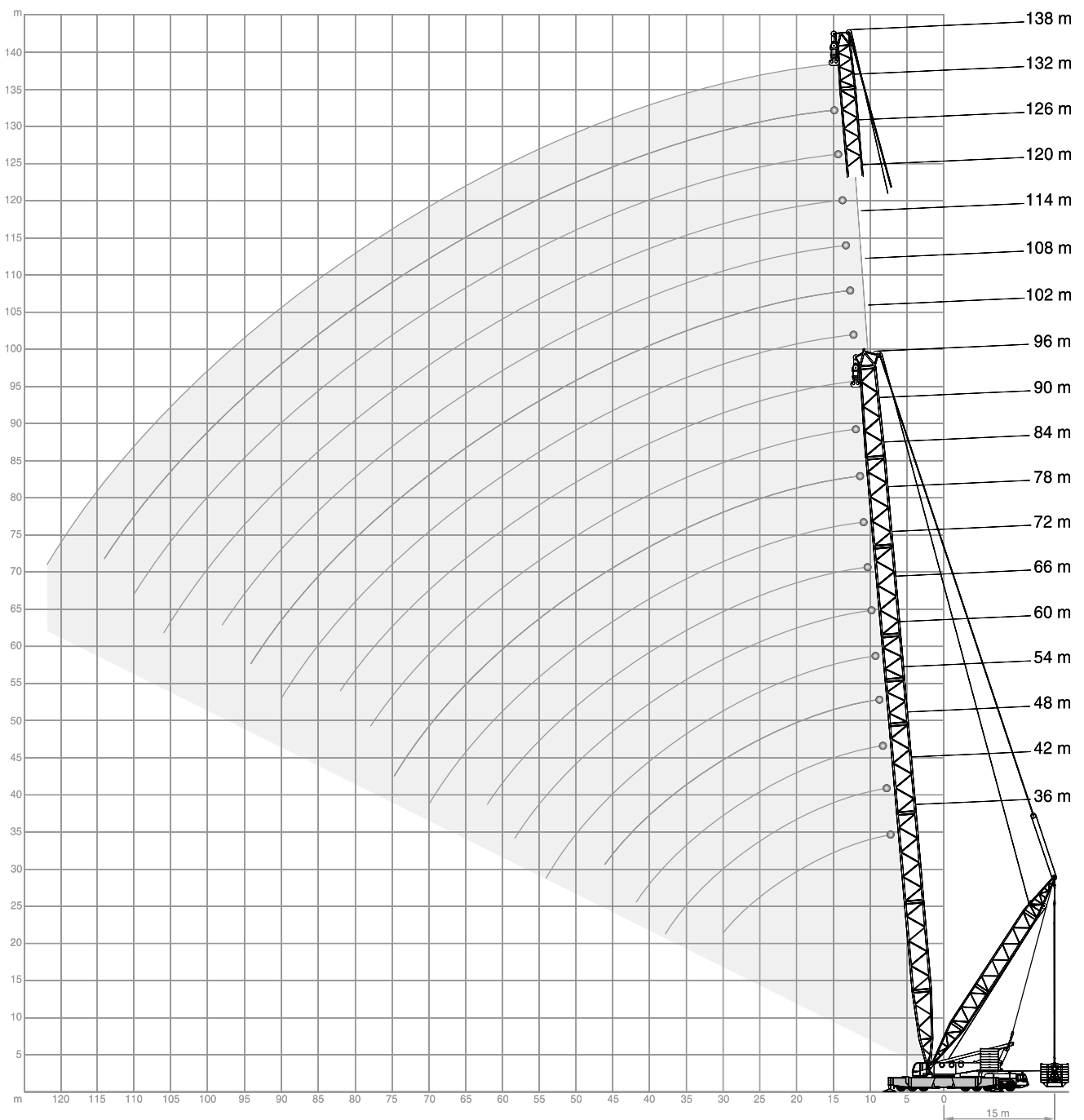

TEREX DEMAG TC 2800-1

AUTOJEŘÁB

//Tomáš Novotný
AUTOJEŘÁBY DEMOLICE s.r.o.

SSL/HSSL LIFTING CAPACITIES · TRAGFÄHIGKEITEN ·
CAPACITÉS DE LEVAGE

160 t		14 m x 14 m				360°				DIN/ISO							
m	36 m				42 m				48 m				54 m				
	SSL		HSSL		SSL		HSSL		SSL		HSSL		SSL		HSSL		
	0 t	0 t-300 t	0 t	0 t-300 t	0 t	0 t-300 t	0 t	0 t-300 t	0 t	0 t-300 t	0 t	0 t-300 t	0 t	0 t-300 t	0 t	0 t-300 t	
	11-15m	17m	11-15m		11-15m	17m	11-15m		11-15m	17m	11-15m		11-15m	17m	11-15m		
	t	t	t	t	t	t	t	t	t	t	t	t	t	t	t	t	t
7	544,0	600,0	600,0	-	-	-	-	-	-	-	-	-	-	-	-	-	-
8	499,0	600,0	600,0	-	496,0	593,0	593,0	-	494,0	580,0	580,0	-	-	-	-	-	-
9	427,0	600,0	600,0	-	425,0	593,0	593,0	-	426,0	580,0	580,0	-	427,0	525,0	525,0	525,0	525,0
10	369,0	599,0	599,0	-	367,0	593,0	593,0	-	367,0	580,0	580,0	-	368,0	525,0	525,0	525,0	525,0
12	289,0	534,0	566,0	-	287,0	531,0	563,0	-	286,0	529,0	560,0	-	286,0	525,0	525,0	525,0	525,0
14	236,0	476,0	504,0	-	233,0	473,0	501,0	-	232,0	470,0	498,0	-	232,0	468,0	496,0	466,0	466,0
16	198,0	428,0	454,0	-	196,0	425,0	451,0	-	194,0	423,0	448,0	-	193,0	421,0	446,0	419,0	419,0
18	170,0	389,0	412,0	-	167,0	386,0	409,0	-	166,0	384,0	407,0	-	165,0	382,0	405,0	380,0	380,0
20	148,0	356,0	371,0	-	146,0	353,0	375,0	-	144,0	351,0	372,0	-	143,0	349,0	371,0	347,0	347,0
22	131,0	323,0	323,0	-	128,0	322,0	343,0	-	127,0	320,0	341,0	-	125,0	318,0	339,0	307,0	307,0
24	118,0	284,0	284,0	-	114,0	294,0	305,0	-	112,0	292,0	311,0	-	111,0	291,0	309,0	275,0	275,0
26	106,0	251,0	251,0	-	104,0	269,0	273,0	-	100,0	267,0	284,0	-	99,5	266,0	284,0	247,0	247,0
28	97,0	228,0	222,0	-	94,0	245,0	245,0	-	91,0	244,0	256,0	-	89,5	244,0	262,0	224,0	224,0
30	88,5	203,0	196,0	-	85,5	220,0	220,0	-	83,5	226,0	234,0	-	80,5	224,0	239,0	205,0	205,0
34	-	-	-	-	71,5	181,0	178,0	-	69,5	194,0	194,0	-	68,0	194,0	202,0	174,0	174,0
38	-	-	-	-	60,5	149,0	143,0	-	58,5	161,0	161,0	-	57,0	170,0	171,0	147,0	147,0
42	-	-	-	-	-	-	-	-	50,0	138,0	133,0	-	48,5	146,0	146,0	125,0	125,0
46	-	-	-	-	-	-	-	-	-	-	-	-	41,9	124,0	123,0	106,0	106,0
49	-	-	-	-	-	-	-	-	-	-	-	-	-	-	-	93,0	93,0

m	60 m				66 m				72 m				78 m				
	SSL		HSSL		SSL		HSSL		SSL		HSSL		SSL		HSSL		
	0 t	0 t-300 t	0 t	0 t-300 t	0 t	0 t-300 t	0 t	0 t-300 t	0 t	0 t-300 t	0 t	0 t-300 t	0 t	0 t-300 t	0 t	0 t-300 t	
	11-15m	17m	11-15m		11-15m	17m	11-15m		11-15m	17m	11-15m		11-15m	17m	11-15m		
	t	t	t	t	t	t	t	t	t	t	t	t	t	t	t	t	t
9	426,0	476,0	476,0	476,0	-	-	-	-	-	-	-	-	-	-	-	-	-
10	368,0	476,0	476,0	476,0	369,0	414,0	414,0	421,0	350,0	373,0	373,0	393,0	-	-	-	-	-
11	327,0	476,0	476,0	476,0	327,0	414,0	414,0	421,0	318,0	373,0	373,0	393,0	-	-	-	364,0	364,0
12	286,0	476,0	476,0	476,0	285,0	414,0	414,0	421,0	286,0	373,0	373,0	393,0	285,0	316,0	316,0	364,0	364,0
14	231,0	466,0	476,0	464,0	231,0	414,0	414,0	421,0	231,0	373,0	373,0	393,0	231,0	316,0	316,0	364,0	364,0
16	193,0	419,0	445,0	417,0	192,0	409,0	409,0	415,0	192,0	373,0	373,0	393,0	191,0	316,0	316,0	364,0	364,0
18	164,0	380,0	403,0	378,0	163,0	378,0	388,0	376,0	163,0	362,0	362,0	374,0	162,0	315,0	315,0	364,0	364,0
20	142,0	347,0	369,0	344,0	141,0	346,0	367,0	335,0	140,0	344,0	345,0	329,0	139,0	306,0	306,0	322,0	322,0
22	124,0	317,0	337,0	305,0	123,0	315,0	336,0	298,0	122,0	314,0	328,0	293,0	121,0	298,0	298,0	286,0	286,0
24	110,0	289,0	308,0	274,0	109,0	287,0	306,0	268,0	108,0	286,0	305,0	264,0	107,0	285,0	290,0	258,0	258,0
26	98,0	265,0	283,0	247,0	97,0	264,0	281,0	243,0	96,0	262,0	279,0	239,0	95,0	261,0	273,0	234,0	234,0
28	88,0	243,0	261,0	225,0	86,5	242,0	259,0	221,0	85,5	242,0	256,0	218,0	84,5	240,0	250,0	214,0	214,0
30	79,5	224,0	240,0	205,0	78,0	223,0	238,0	203,0	77,0	222,0	235,0	200,0	76,0	222,0	231,0	196,0	196,0
34	65,5	192,0	204,0	174,0	64,0	191,0	204,0	172,0	63,0	191,0	202,0	171,0	61,5	190,0	199,0	168,0	168,0
38	55,5	169,0	176,0	150,0	53,5	167,0	176,0	148,0	52,0	166,0	176,0	148,0	50,5	166,0	173,0	146,0	146,0
42	47,1	150,0	152,0	130,0	45,8	149,0	155,0	130,0	43,5	147,0	154,0	128,0	42,2	146,0	153,0	127,0	127,0
46	40,3	131,0	131,0	112,0	38,8	133,0	135,0	113,0	37,2	132,0	137,0	114,0	35,9	131,0	136,0	113,0	113,0
50	34,8	113,0	113,0	96,5	33,1	118,0	118,0	99,5	31,4	119,0	121,0	100,0	30,0	118,0	121,0	100,0	100,0
54	30,3	100,0	96,5	82,0	28,4	103,0	103,0	86,5	26,6	107,0	107,0	88,5	25,1	107,0	108,0	89,0	89,0
58	-	-	-	-	24,6	91,0	89,5	75,0	22,6	94,5	94,5	78,0	21,0	96,5	96,5	79,0	79,0
59	-	-	-	-	-	-	-	72,0	21,7	91,5	91,5	75,5	20,1	93,7	93,7	76,7	76,7
62	-	-	-	-	-	-	-	-	19,3	82,5	82,5	68,0	17,5	85,5	85,5	70,0	70,0
65	-	-	-	-	-	-	-	-	-	-	-	61,0	15,3	78,0	78,0	63,6	63,6
66	-	-	-	-	-	-	-	-	-	-	-	-	14,6	75,5	75,5	61,5	61,5
70	-	-	-	-	-	-	-	-	-	-	-	-	12,2	69,0	66,0	53,5	53,5

Remarks · Bemerkungen · Remarques

For HSSL a boom power-kit is required

Für HSSL ist ein Ausleger-Verstärkungs-Kit erforderlich

Un kit à fortifier de flèche principale est nécessaire pour HSSL

TEREX DEMAG TC 2800-1

AUTOJEŘÁB

//Tomáš Novotný
AUTOJEŘÁBY DEMOLICE s.r.o.

SSL/HSSL LIFTING CAPACITIES · TRAGFÄHIGKEITEN · CAPACITÉS DE LEVAGE

160 t		14 m x 14 m								360°				DIN/ISO	
m	84 m				90 m				96 m				102 m	108 m	
	SSL		HSSL		SSL		HSSL		SSL		HSSL		HSSL	HSSL	
	0 t	0 t-300 t	0 t	0 t-300 t	0 t	0 t-300 t	0 t	0 t-300 t	0 t	0 t-300 t	0 t-300 t	0 t-300 t	0 t-300 t	0 t-300 t	
	11-15m	17m	11-15m	11-15m	17m	11-15m	11-15m	17m	11-15m	17m	11-15m	11-15m	11-15m	11-15m	
t	t	t	t	t	t	t	t	t	t	t	t	t	t	t	
11	-	-	-	307,0	-	-	-	-	-	-	-	-	-	-	
12	272,0	281,0	281,0	307,0	233,0	238,0	238,0	289,0	203,0	208,0	208,0	253,0	-	-	
13	249,0	281,0	281,0	307,0	225,0	238,0	238,0	288,5	203,0	208,0	208,0	252,5	218,0	191,0	
14	226,0	281,0	281,0	307,0	217,0	238,0	238,0	288,0	203,0	208,0	208,0	252,0	218,0	191,0	
16	189,0	281,0	281,0	307,0	185,0	238,0	238,0	287,0	178,0	208,0	208,0	250,0	215,0	189,0	
18	160,0	281,0	281,0	307,0	159,0	238,0	238,0	286,0	154,0	208,0	208,0	248,0	212,0	187,0	
20	137,0	278,0	278,0	307,0	137,0	237,0	237,0	284,0	136,0	208,0	208,0	246,0	210,0	184,0	
22	119,0	271,0	271,0	276,0	119,0	233,0	233,0	271,0	117,0	205,0	205,0	242,0	208,0	182,0	
24	105,0	265,0	265,0	248,0	104,0	229,0	229,0	243,0	103,0	201,0	201,0	236,0	203,0	179,0	
26	92,5	259,0	259,0	226,0	91,5	225,0	225,0	221,0	90,5	197,0	197,0	215,0	198,0	174,0	
28	82,5	238,0	241,0	206,0	81,5	220,0	220,0	202,0	80,0	193,0	193,0	196,0	191,0	170,0	
30	73,5	220,0	223,0	190,0	72,5	212,0	212,0	186,0	71,5	189,0	189,0	180,0	175,0	165,0	
34	59,5	188,0	192,0	162,0	58,5	188,0	188,0	159,0	57,0	176,0	176,0	154,0	150,0	144,0	
38	48,6	164,0	168,0	141,0	47,5	163,0	164,0	138,0	46,0	160,0	160,0	134,0	130,0	125,0	
42	39,9	145,0	148,0	124,0	38,7	144,0	145,0	122,0	37,2	142,0	142,0	117,0	115,0	110,0	
46	32,8	129,0	132,0	109,0	31,6	128,0	130,0	107,0	30,0	127,0	127,0	104,0	101,0	97,0	
50	27,7	116,0	119,0	97,5	25,7	115,0	116,0	95,5	24,1	113,0	114,0	92,5	90,5	86,5	
54	22,7	105,0	106,0	86,5	21,4	104,0	105,0	86,0	19,1	102,0	102,0	82,5	81,0	77,0	
58	18,6	95,5	95,5	77,5	17,2	94,5	95,0	76,5	15,5	93,0	93,0	74,0	72,5	69,0	
62	15,0	85,5	85,5	69,0	13,6	85,5	85,5	69,0	11,9	84,0	84,0	66,0	65,5	62,5	
66	12,0	76,5	76,5	61,5	10,5	77,0	77,0	62,0	8,7	76,0	76,0	59,5	58,5	56,0	
70	9,5	68,0	68,0	54,5	7,9	69,0	69,0	55,0	6,0	69,0	69,0	53,0	52,5	50,0	
74	7,4	62,0	60,0	47,7	5,6	62,0	62,0	49,3	-	62,0	62,0	47,7	47,6	45,0	
75	-	-	-	46,1	-	60,2	60,2	47,8	-	60,3	60,3	46,3	46,3	43,8	
78	-	-	-	-	-	56,0	55,0	43,4	-	55,5	55,5	42,3	42,6	40,4	
80	-	-	-	-	-	-	-	40,5	-	52,5	52,5	39,7	40,3	38,2	
82	-	-	-	-	-	-	-	-	-	50,5	49,5	37,2	38,0	36,1	
85	-	-	-	-	-	-	-	-	-	-	-	33,5	34,7	33,0	
86	-	-	-	-	-	-	-	-	-	-	-	-	33,6	32,0	
90	-	-	-	-	-	-	-	-	-	-	-	-	29,3	28,2	
91	-	-	-	-	-	-	-	-	-	-	-	-	28,2	27,2	
94	-	-	-	-	-	-	-	-	-	-	-	-	-	24,4	
96	-	-	-	-	-	-	-	-	-	-	-	-	-	22,6	

Remarks · Bemerkungen · Remarques

For HSSL a boom power-kit is required

Für HSSL ist ein Ausleger-Verstärkungs-Kit erforderlich

Un kit à fortifier de flèche principale est nécessaire pour HSSL

TEREX DEMAG TC 2800-1

AUTOJEŘÁB

//Tomáš Novotný
AUTOJEŘÁBY DEMOLICE s.r.o.

SSL/LSL LIFTING CAPACITIES · TRAGFÄHIGKEITEN · CAPACITÉS DE LEVAGE

160 t		11-15 m		14 m x 14 m		360°		DIN/ISO	
m	90 m		96 m		102 m				
	0 t	0 t-300 t	0 t	0 t-300 t	0 t	0 t-300 t	0 t	0 t-300 t	SSL/LSL SGLmax.
12	239,0	248,0	249,0	207,0	215,0	224,0	-	-	-
13	230,0	248,0	249,0	206,5	214,5	223,0	-	-	204,0
14	221,0	248,0	249,0	206,0	214,0	222,0	173,0	181,0	203,0
16	189,0	248,0	249,0	183,0	213,0	220,0	171,0	179,0	199,0
18	164,0	248,0	249,0	159,0	212,0	217,0	155,0	178,0	196,0
20	144,0	246,0	247,0	141,0	211,0	215,0	137,0	176,0	193,0
22	126,0	241,0	241,0	125,0	209,0	210,0	122,0	174,0	190,0
24	111,0	235,0	236,0	111,0	205,0	205,0	109,0	172,0	185,0
26	99,0	230,0	230,0	99,0	202,0	200,0	98,5	170,0	180,0
28	89,0	224,0	211,0	88,5	199,0	195,0	88,0	168,0	175,0
30	80,0	212,0	195,0	79,5	194,0	188,0	79,5	166,0	170,0
34	66,0	191,0	169,6	65,5	178,0	165,3	65,0	156,0	156,6
38	54,5	169,0	148,0	54,0	163,0	145,3	54,0	145,0	141,6
42	46,1	149,0	130,0	45,5	148,0	128,0	45,1	134,0	125,0
46	38,9	133,0	116,6	38,3	133,0	114,6	37,8	124,0	111,6
50	33,0	120,0	104,8	32,3	120,0	102,8	31,8	114,0	100,1
54	28,6	109,0	94,5	27,3	108,0	92,5	26,8	107,0	90,5
58	24,3	100,0	85,1	23,6	99,5	84,1	22,4	98,5	82,5
62	20,6	91,5	77,1	19,8	91,0	76,3	19,2	91,0	74,8
66	17,3	84,0	69,5	16,6	83,0	69,0	16,0	83,5	67,5
70	14,5	76,0	63,1	13,7	76,0	63,0	13,1	77,0	61,5
74	12,0	68,5	56,8	11,2	69,0	57,1	10,5	70,0	56,0
78	9,9	61,0	50,5	9,0	63,0	51,5	8,3	64,0	51,0
80	-	-	47,7	8,0	59,7	48,9	7,3	61,0	48,6
82	-	-	-	7,0	56,5	46,3	6,3	58,0	46,2
85	-	-	-	-	-	42,5	4,9	53,8	42,6
86	-	-	-	-	-	-	4,5	52,5	41,4
90	-	-	-	-	-	-	-	48,3	36,8

m	108 m		114 m		120 m				
	0 t	0 t-300 t	0 t	0 t-300 t	0 t	0 t-300 t	0 t	0 t-300 t	SSL/LSL SGLmax.
13	-	-	183,0	-	-	-	-	-	-
14	147,0	153,0	183,0	129,0	134,0	162,0	119,0	122,0	146,0
16	143,0	150,0	181,0	126,0	132,0	161,0	117,0	121,0	146,0
18	139,0	147,0	180,0	124,0	131,0	160,0	115,0	120,0	145,0
20	133,0	145,0	178,0	121,0	129,0	159,0	112,0	118,0	144,0
22	118,0	142,0	176,0	115,0	127,0	158,0	110,0	117,0	143,0
24	106,0	139,0	174,0	103,0	126,0	157,0	101,0	115,0	142,0
26	96,5	136,0	171,0	94,0	124,0	155,0	92,0	114,0	141,0
28	87,0	133,0	169,0	85,5	122,0	154,0	83,5	112,0	140,0
30	78,0	130,0	166,0	78,0	120,0	152,0	76,5	111,0	138,0
34	64,0	124,0	150,6	63,5	117,0	144,6	63,5	107,0	134,6
38	52,5	119,0	136,6	52,5	113,0	133,0	52,0	104,0	126,0
42	43,9	114,0	120,0	43,6	108,0	117,0	43,4	100,0	112,0
46	36,7	108,0	107,3	36,3	104,0	104,6	36,1	97,0	100,3
50	30,6	103,0	96,1	30,3	99,0	93,6	30,0	93,0	89,8
54	25,6	98,0	86,5	25,2	95,0	84,0	24,9	90,0	80,5
58	21,2	93,0	78,5	20,8	91,0	76,3	20,6	86,0	72,8
62	18,0	88,0	71,3	17,0	86,0	69,3	16,8	82,0	65,8
66	14,7	82,0	65,0	14,3	81,5	63,0	13,5	79,0	59,5
70	11,8	75,5	59,0	11,4	74,5	57,3	11,1	73,5	54,5
74	9,3	69,0	53,5	8,8	68,5	52,0	8,5	68,0	49,7
78	7,0	63,5	48,7	6,5	63,0	47,1	6,2	62,5	45,1
82	5,0	58,0	44,3	4,4	58,0	42,8	4,2	58,0	40,8
86	-	53,0	40,0	-	53,0	38,7	-	53,0	36,8
90	-	48,0	35,9	-	48,8	34,9	-	49,1	33,2
94	-	44,0	31,8	-	44,3	31,2	-	45,0	29,8
96	-	-	29,8	-	42,5	29,4	-	43,0	28,2
98	-	-	-	-	41,1	27,6	-	41,0	26,5
101	-	-	-	-	-	24,9	-	38,7	24,1
102	-	-	-	-	-	-	-	38,0	23,3
106	-	-	-	-	-	-	-	34,6	20,2

TEREX DEMAG TC 2800-1

AUTOJEŘÁB

//Tomáš Novotný
AUTOJEŘÁBY DEMOLICE s.r.o.

SSL/LSL LIFTING CAPACITIES · TRAGFÄHIGKEITEN · CAPACITÉS DE LEVAGE

160 t			11-15 m			14 m x 14 m			360°			DIN/ISO					
126 m			132 m			138 m											
SSL/LSL			SSL/LSL SGLmax.			SSL/LSL			SSL/LSL SGLmax.			SSL/LSL			SSL/LSL SGLmax.		
0 t			0 t-300 t			0 t			0 t-300 t			0 t			0 t-300 t		
m	t	t	t	t	t	t	t	t	t	t	t	t	t	t	t	t	t
15	-	-	129,0	-	-	117,0	-	-	-	-	-	-	-	-	-	-	-
16	106,0	109,0	129,0	92,0	96,0	117,0	79,0	82,0	103,0	-	-	-	-	-	-	-	-
18	104,0	108,0	128,0	90,0	95,0	116,0	77,0	80,0	102,0	-	-	-	-	-	-	-	-
20	103,0	108,0	127,0	88,0	94,0	115,0	74,0	79,0	101,0	-	-	-	-	-	-	-	-
22	102,0	107,0	126,0	87,0	93,0	114,0	72,0	78,0	100,0	-	-	-	-	-	-	-	-
24	99,0	106,0	125,0	85,0	92,0	113,0	70,0	77,0	99,0	-	-	-	-	-	-	-	-
26	89,5	105,0	124,0	84,0	91,0	112,0	69,0	75,0	98,0	-	-	-	-	-	-	-	-
28	81,5	104,0	124,0	79,0	90,0	111,0	67,0	74,0	97,0	-	-	-	-	-	-	-	-
30	74,5	103,0	123,0	72,0	89,0	110,0	66,0	73,0	95,5	-	-	-	-	-	-	-	-
34	62,5	101,0	121,0	60,5	87,0	108,0	59,0	71,0	93,5	-	-	-	-	-	-	-	-
38	52,0	99,0	116,3	50,5	86,0	105,3	50,0	68,0	91,3	-	-	-	-	-	-	-	-
42	43,1	97,0	109,0	41,9	85,0	102,0	41,0	66,0	89,0	-	-	-	-	-	-	-	-
46	35,8	94,0	97,6	34,5	83,0	92,6	33,7	63,0	85,3	-	-	-	-	-	-	-	-
50	29,7	91,0	87,3	28,4	82,0	83,3	27,5	61,0	79,1	-	-	-	-	-	-	-	-
54	24,5	88,0	78,0	23,3	80,0	74,0	22,4	58,0	70,5	-	-	-	-	-	-	-	-
58	20,2	85,0	70,6	18,9	78,0	67,0	18,0	55,0	63,5	-	-	-	-	-	-	-	-
62	16,4	82,0	63,8	15,1	75,0	60,5	14,2	52,0	57,0	-	-	-	-	-	-	-	-
66	13,1	78,5	57,5	11,8	73,0	54,5	10,9	49,0	51,0	-	-	-	-	-	-	-	-
70	10,2	72,0	52,3	8,9	69,5	49,3	7,9	46,0	46,2	-	-	-	-	-	-	-	-
74	8,0	67,0	47,7	6,3	64,5	44,7	5,4	42,0	41,9	-	-	-	-	-	-	-	-
78	5,7	62,0	43,3	4,4	60,0	40,6	-	39,0	37,9	-	-	-	-	-	-	-	-
82	-	57,5	39,1	-	55,5	36,6	-	36,0	33,9	-	-	-	-	-	-	-	-
86	-	53,0	35,2	-	51,0	32,8	-	33,9	30,4	-	-	-	-	-	-	-	-
90	-	48,9	31,5	-	47,4	29,3	-	32,9	27,0	-	-	-	-	-	-	-	-
94	-	45,0	28,3	-	43,7	26,1	-	31,9	23,9	-	-	-	-	-	-	-	-
98	-	41,3	25,2	-	40,2	23,1	-	30,9	20,9	-	-	-	-	-	-	-	-
102	-	37,8	22,3	-	36,8	20,3	-	29,8	18,2	-	-	-	-	-	-	-	-
106	-	35,1	19,3	-	33,6	17,7	-	28,8	15,7	-	-	-	-	-	-	-	-
110	-	31,8	16,5	-	30,6	15,1	-	27,8	13,3	-	-	-	-	-	-	-	-
111	-	-	15,8	-	29,9	14,4	-	27,5	12,7	-	-	-	-	-	-	-	-
114	-	-	-	-	28,1	12,5	-	26,8	11,0	-	-	-	-	-	-	-	-
116	-	-	-	-	-	11,2	-	25,6	9,8	-	-	-	-	-	-	-	-
118	-	-	-	-	-	-	-	24,4	8,6	-	-	-	-	-	-	-	-
122	-	-	-	-	-	-	-	22,6	6,4	-	-	-	-	-	-	-	-
126	-	-	-	-	-	-	-	-	-	-	-	-	-	-	-	-	-

Remarks · Bemerkungen · Remarques

For SSL/LSL SGLmax. a boom power-kit is required

Für SSL/LSL SGLmax. ist ein Ausleger-Verstärkungs-Kit erforderlich

Un kit à fortifier de flèche principale est nécessaire pour SSL/LSL SGLmax.

TEREX DEMAG TC 2800-1

AUTOJEŘÁB

//Tomáš Novotný
AUTOJEŘÁBY DEMOLICE s.r.o.

SH+LF2, SH/LH+LF2 WORKING RANGES · ARBEITSBEREICHE ·
PORTÉES

10°

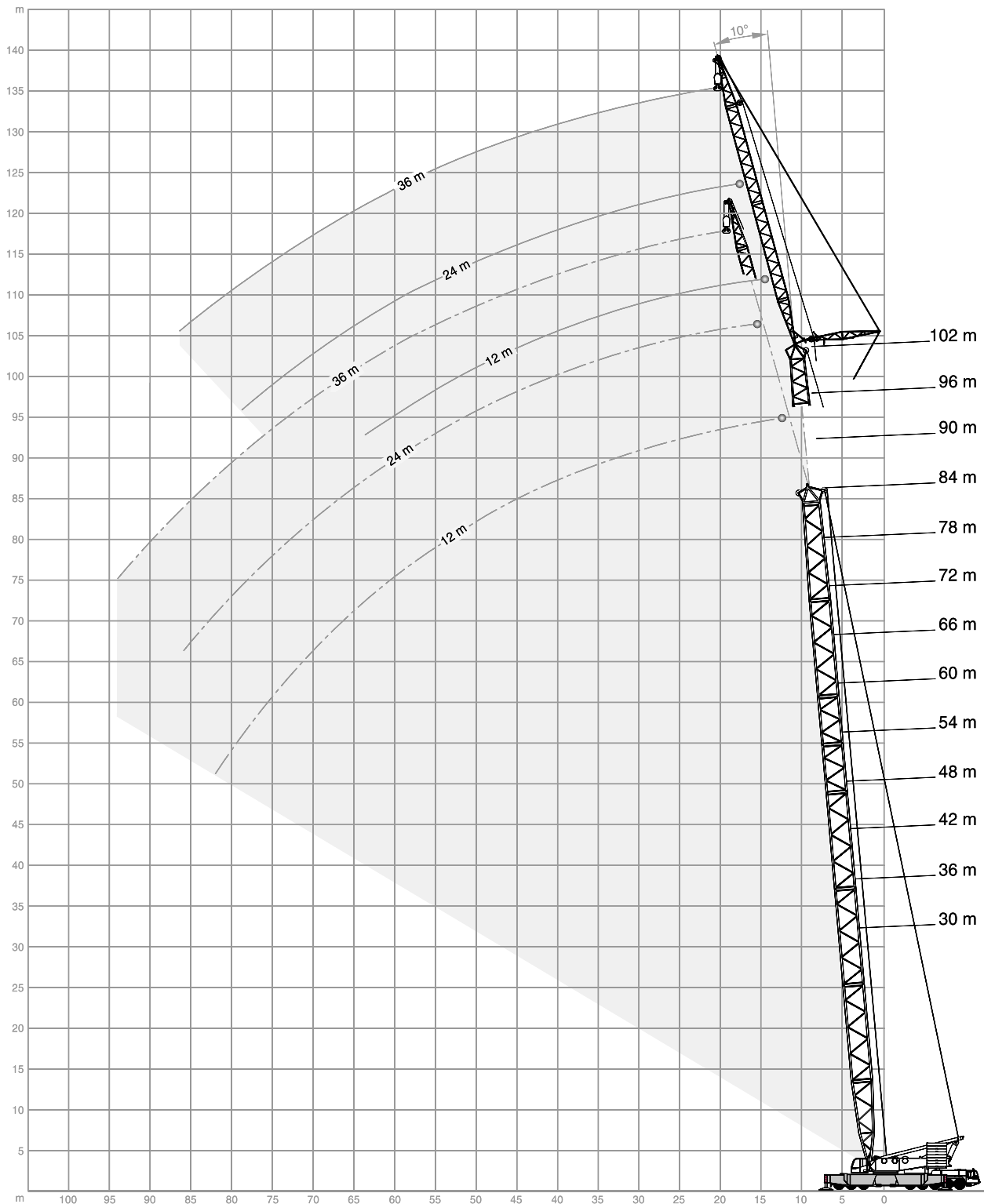

TEREX DEMAG TC 2800-1

AUTOJEŘÁB

//Tomáš Novotný
AUTOJEŘÁBY DEMOLICE s.r.o.

SH+LF2 LIFTING CAPACITIES · TRAGFÄHIGKEITEN ·
CAPACITÉS DE LEVAGE

		200 t			12 m			14 m x 14 m			360°			DIN/ISO		
		30 m			36 m			42 m			48 m			54 m		
		10°	15°	20°	10°	15°	20°	10°	15°	20°	10°	15°	20°	10°	15°	20°
m	t	t	t	t	t	t	t	t	t	t	t	t	t	t	t	t
9	125,0	-	-	125,0	-	-	-	-	-	-	-	-	-	-	-	-
10	125,0	107,0	-	125,0	108,0	-	125,0	-	-	125,0	-	-	-	-	-	-
11	124,0	101,0	81,0	125,0	105,0	83,5	125,0	109,0	-	125,0	109,0	-	125,0	-	-	-
12	119,0	94,5	77,0	123,0	99,5	79,5	125,0	103,0	81,5	125,0	106,0	82,0	125,0	109,0	-	-
13	111,0	89,5	73,0	120,0	94,0	76,0	123,0	98,5	78,5	124,0	102,0	80,5	125,0	105,0	82,0	-
14	104,0	84,5	70,0	113,0	89,5	73,0	120,0	93,5	75,5	122,0	97,5	77,5	124,0	100,0	79,0	-
16	93,0	76,5	64,0	100,0	81,5	67,0	108,0	86,0	70,0	114,0	89,5	72,0	119,0	93,0	74,0	-
18	83,5	70,0	59,0	91,0	74,5	62,5	98,0	79,0	65,0	104,0	83,0	67,5	110,0	86,5	70,0	-
20	75,5	64,0	55,0	83,0	69,0	58,5	89,5	73,5	61,0	95,5	77,0	63,5	101,0	80,5	66,0	-
22	68,5	59,5	51,5	76,0	64,0	54,5	82,5	68,5	57,5	88,5	72,5	60,0	94,0	76,0	62,5	-
24	64,0	55,5	48,5	69,5	60,0	51,5	76,5	64,0	54,5	82,5	68,0	57,0	87,5	71,5	59,5	-
26	59,5	52,0	45,8	65,0	56,5	49,0	70,5	60,5	51,5	76,5	64,0	54,5	82,0	67,5	56,5	-
28	55,5	49,2	43,5	61,5	53,0	46,6	66,0	57,0	49,4	71,5	61,0	52,0	76,5	64,0	54,0	-
30	52,5	46,5	41,4	58,0	50,5	44,4	63,0	54,0	47,2	67,0	57,5	49,7	72,0	61,0	52,0	-
34	46,9	42,2	38,1	51,5	45,9	40,8	56,5	49,5	43,4	61,0	52,5	45,8	64,5	55,5	48,0	-
38	42,6	38,9	35,6	47,1	42,2	38,0	51,0	45,5	40,4	55,5	48,5	42,6	59,5	51,0	44,7	-
39	41,8	38,3	-	46,1	41,4	37,4	50,0	44,6	39,7	54,3	47,6	41,9	58,2	50,2	44,0	-
40	-	37,7	-	45,2	40,7	36,9	49,1	43,8	39,1	53,2	46,8	41,3	57,0	49,4	43,3	-
42	-	-	-	43,3	39,3	35,8	47,2	42,2	37,9	51,0	45,1	40,0	54,5	47,8	42,0	-
43	-	-	-	42,5	38,7	35,4	46,3	41,5	37,4	50,0	44,3	39,4	53,5	47,0	41,4	-
45	-	-	-	41,0	37,7	-	44,5	40,2	36,4	48,1	42,9	38,3	51,5	45,4	40,2	-
46	-	-	-	-	-	-	43,7	39,6	36,0	47,2	42,2	37,8	50,5	44,7	39,6	-
48	-	-	-	-	-	-	42,3	38,6	35,2	45,6	41,0	36,9	48,1	43,4	38,6	-
50	-	-	-	-	-	-	41,0	37,6	-	44,1	39,8	36,1	45,8	42,1	37,7	-
53	-	-	-	-	-	-	-	-	-	42,1	38,3	35,0	41,8	40,5	36,5	-
54	-	-	-	-	-	-	-	-	-	41,5	37,9	-	40,5	40,0	36,1	-
55	-	-	-	-	-	-	-	-	-	40,5	37,5	-	39,4	39,0	35,8	-
58	-	-	-	-	-	-	-	-	-	-	-	-	36,1	36,2	34,9	-
60	-	-	-	-	-	-	-	-	-	-	-	-	34,2	34,2	-	-
61	-	-	-	-	-	-	-	-	-	-	-	-	-	33,3	-	-
62	-	-	-	-	-	-	-	-	-	-	-	-	-	-	-	-

TEREX DEMAG TC 2800-1

AUTOJEŘÁB

//Tomáš Novotný
AUTOJEŘÁBY DEMOLICE s.r.o.

SH+LF2 LIFTING CAPACITIES · TRAGFÄHIGKEITEN ·
CAPACITÉS DE LEVAGE

200 t		12 m		14 m x 14 m		360°		DIN/ISO							
m	60 m			66 m			72 m			78 m			84 m		
	10°	15°	20°	10°	15°	20°	10°	15°	20°	10°	15°	20°	10°	15°	20°
11	t	t	t	t	t	t	t	t	t	t	t	t	t	t	t
12	125,0	-	-	-	-	-	-	-	-	-	-	-	-	-	-
13	125,0	108,0	-	125,0	-	-	125,0	-	-	-	-	-	-	-	-
14	125,0	107,0	81,5	125,0	106,0	-	125,0	108,0	81,5	125,0	106,0	-	125,0	104,0	-
15	125,0	103,0	80,5	125,0	106,0	80,5	125,0	108,0	81,5	125,0	106,0	80,0	125,0	104,0	79,0
16	124,0	99,5	78,0	125,0	102,0	79,5	125,0	104,0	81,0	125,0	106,0	80,0	125,0	104,0	79,0
18	121,0	96,0	76,0	124,0	98,5	77,5	125,0	101,0	78,5	125,0	103,0	80,0	125,0	104,0	79,0
20	115,0	89,5	71,5	118,0	92,5	73,5	121,0	95,0	74,5	124,0	97,0	76,0	125,0	99,0	77,0
22	106,0	84,0	68,0	111,0	86,5	69,5	115,0	89,5	71,0	118,0	91,5	72,5	121,0	94,0	74,0
24	99,0	79,0	64,5	104,0	82,0	66,0	108,0	84,5	68,0	112,0	87,0	69,5	115,0	89,0	70,5
26	92,5	74,5	61,5	97,0	77,5	63,0	101,0	80,0	65,0	105,0	82,5	66,5	109,0	85,0	68,0
28	86,5	70,5	58,5	91,5	73,5	60,5	95,5	76,0	62,0	99,5	78,5	64,0	103,0	81,0	65,0
30	81,5	67,0	56,0	86,0	70,0	58,0	90,0	72,5	59,5	94,0	75,0	61,5	98,0	77,5	63,0
34	77,0	64,0	54,0	81,5	67,0	55,5	85,5	69,5	57,5	89,5	72,0	59,0	93,0	74,0	60,5
38	68,5	58,5	50,0	73,0	61,0	51,5	76,5	63,5	53,5	78,5	66,0	55,0	77,5	68,5	56,5
42	62,5	54,0	46,7	66,0	56,5	48,5	66,5	59,0	50,0	65,5	61,5	51,5	64,0	63,5	53,0
46	58,0	50,0	43,8	57,5	52,5	45,6	56,5	55,0	47,2	55,5	56,0	48,8	54,0	54,5	50,0
50	50,5	47,1	41,4	49,8	49,5	43,1	48,5	48,9	44,7	47,5	47,9	46,2	46,2	46,6	47,1
54	44,4	44,4	39,3	43,4	43,7	40,9	42,0	42,4	42,4	41,0	41,3	41,7	39,6	40,0	40,4
58	39,1	39,3	37,6	38,0	38,3	38,5	36,7	36,9	37,2	35,6	35,9	36,2	34,0	34,4	34,7
62	34,6	34,8	35,0	33,6	33,8	34,0	32,0	32,3	32,6	30,7	31,1	31,4	29,1	29,5	29,8
63	30,9	31,0	31,1	29,6	29,8	30,0	28,0	28,2	28,4	26,6	26,9	27,2	25,0	25,3	25,6
65	30,0	30,1	30,2	28,7	28,9	29,1	27,1	27,3	27,5	25,7	26,0	26,3	24,1	24,4	24,7
66	28,3	28,4	-	27,0	27,1	27,3	25,3	25,5	25,7	23,9	24,2	24,5	22,3	22,6	22,9
68	-	27,6	-	26,2	26,3	26,5	24,5	24,7	24,8	23,1	23,3	23,6	21,4	21,7	22,0
70	-	-	-	24,7	24,8	24,9	22,9	23,1	23,2	21,6	21,8	22,0	19,9	20,1	20,4
71	-	-	-	23,2	23,3	-	21,4	21,6	21,7	20,1	20,3	20,4	18,4	18,6	18,8
73	-	-	-	22,5	22,6	-	20,7	20,9	21,0	19,4	19,6	19,7	17,7	17,9	18,1
74	-	-	-	-	-	-	19,4	19,5	19,7	18,0	18,2	18,3	16,3	16,5	16,7
76	-	-	-	-	-	-	18,8	18,9	-	17,4	17,6	17,7	15,7	15,9	16,1
77	-	-	-	-	-	-	17,6	17,7	-	16,2	16,4	16,5	14,5	14,7	14,8
78	-	-	-	-	-	-	-	-	-	15,1	15,2	15,3	13,3	13,5	13,6
81	-	-	-	-	-	-	-	-	-	13,5	13,6	-	11,7	11,9	12,0
82	-	-	-	-	-	-	-	-	-	-	-	-	11,2	11,4	11,5
83	-	-	-	-	-	-	-	-	-	-	-	-	10,7	10,9	11,0
86	-	-	-	-	-	-	-	-	-	-	-	-	9,4	9,5	-
87	-	-	-	-	-	-	-	-	-	-	-	-	-	9,1	-
90	-	-	-	-	-	-	-	-	-	-	-	-	-	-	-

3

TEREX DEMAG TC 2800-1

AUTOJEŘÁB

//Tomáš Novotný
AUTOJEŘÁBY DEMOLICE s.r.o.

SH/LH+LF2 LIFTING CAPACITIES · TRAGFÄHIGKEITEN · CAPACITÉS DE LEVAGE

200 t		12 m		14 m x 14 m		360°		DIN/ISO					
m	66 m			72 m			78 m						
	SH/LH+LF2			SH/LH+LF2			SH/LH+LF2	SH/LH+LF2	SH/LH+LF2	SH/LH+LF2	SH/LH+LF2	SH/LH+LF2	
	10°	15°	20°	10°	15°	20°	LF2	SGLmax.	LF2	SGLmax.	LF2	SGLmax.	
t	t	t	t	t	t	t	t	t	t	t	t	t	
12	125,0	-	-	125,0	-	-	-	-	-	-	-	-	-
13	125,0	111,0	-	125,0	107,0	-	116,0	125,0	-	-	-	-	-
14	125,0	107,0	83,0	125,0	107,0	79,5	116,0	125,0	101,0	122,0	-	-	-
15	125,0	103,0	80,5	125,0	103,0	79,5	114,0	125,0	101,0	118,0	78,0	91,0	-
16	125,0	99,5	78,0	125,0	100,0	77,5	112,0	125,0	99,5	114,0	78,0	88,5	-
18	121,0	93,5	74,0	120,0	94,5	74,0	109,0	125,0	95,0	107,0	74,5	84,5	-
20	112,0	87,5	70,0	114,0	89,5	71,0	106,0	122,0	91,0	101,0	71,5	80,5	-
22	104,0	82,5	67,0	109,0	85,0	67,5	104,0	115,0	86,5	96,5	68,5	77,0	-
24	98,0	78,5	64,0	102,0	81,0	65,5	99,5	106,0	83,0	91,5	66,0	74,0	-
26	92,0	74,5	61,0	96,0	77,0	63,0	95,5	97,0	79,5	87,5	64,0	71,0	-
28	86,5	70,5	58,5	91,0	73,5	60,5	91,5	89,0	76,0	83,5	62,0	68,0	-
30	82,0	67,5	56,0	86,0	70,0	58,0	87,5	81,5	72,5	80,0	59,5	65,5	-
34	74,0	62,0	52,0	78,0	64,5	54,0	79,0	68,0	67,0	73,5	55,5	61,5	-
38	67,5	57,0	49,0	68,0	59,5	50,5	67,5	57,0	61,5	67,0	52,0	57,5	-
42	58,5	53,0	46,0	58,0	55,5	47,7	57,5	48,8	56,0	57,0	49,2	53,5	-
46	50,5	50,0	43,5	50,0	50,5	45,1	49,6	42,4	50,0	49,2	46,6	48,0	-
50	44,4	44,7	41,3	43,7	44,0	42,8	43,1	38,4	43,4	42,6	43,7	42,2	-
54	39,1	39,3	39,4	38,3	38,6	38,8	37,7	36,0	38,0	36,3	38,2	36,5	-
58	34,6	34,8	34,9	33,8	34,0	34,2	33,2	32,1	33,4	32,5	33,7	32,7	-
62	30,8	30,9	31,1	29,9	30,1	30,3	29,1	28,0	29,4	28,3	29,6	28,5	-
66	27,4	27,5	27,6	26,4	26,6	26,8	25,6	24,5	25,8	24,7	26,0	24,9	-
68	25,9	26,0	26,1	24,9	25,0	25,2	24,1	22,9	24,3	23,1	24,4	23,3	-
70	24,4	24,5	-	23,4	23,5	23,7	22,6	21,4	22,8	21,6	22,9	21,8	-
71	23,7	23,8	-	22,7	22,8	23,0	21,9	20,7	22,1	20,9	22,2	21,1	-
73	-	-	-	21,4	21,5	21,6	20,5	19,3	20,7	19,5	20,8	19,7	-
74	-	-	-	20,8	20,9	-	19,9	18,7	20,1	18,9	20,2	19,0	-
76	-	-	-	19,6	19,7	-	18,7	17,5	18,9	17,7	19,0	17,8	-
77	-	-	-	-	19,1	-	18,1	16,9	18,3	17,1	18,4	17,2	-
78	-	-	-	-	-	-	17,6	16,4	17,7	16,5	17,8	16,6	-
81	-	-	-	-	-	-	16,0	14,8	16,1	14,9	-	-	-
82	-	-	-	-	-	-	-	-	15,6	14,4	-	-	-

Remarks · Bemerkungen · Remarques

For SH/LH+LF2 SGLmax. a boom power-kit is required
Für SH/LH+LF2 SGLmax. ist ein Ausleger-Verstärkungs-Kit erforderlich
Un kit à fortifier de flèche principale est nécessaire pour SH/LH+LF2 SGLmax.

TEREX DEMAG TC 2800-1

AUTOJEŘÁB

//Tomáš Novotný
AUTOJEŘÁBY DEMOLICE s.r.o.

SH/LH+LF2 LIFTING CAPACITIES · TRAGFÄHIGKEITEN · CAPACITÉS DE LEVAGE

200 t 12 m 14 m x 14 m 360° DIN/ISO

m	84 m						90 m						
	SH/LH+LF2	SH/LH+LF2 SGLmax.	SH/LH+LF2	SH/LH+LF2 SGLmax.	SH/LH+LF2	SH/LH+LF2 SGLmax.	SH/LH+LF2	SH/LH+LF2 SGLmax.	SH/LH+LF2	SH/LH+LF2 SGLmax.	SH/LH+LF2	SH/LH+LF2 SGLmax.	
	10°		15°		20°		10°		15°		20°		
t	t	t	t	t	t	t	t	t	t	t	t	t	
14	107,0	125,0	-	-	-	-	91,0	125,0	-	-	-	-	-
15	107,0	125,0	96,0	119,0	83,5	-	91,0	125,0	83,5	118,0	-	-	-
16	106,0	125,0	96,0	116,0	81,5	89,5	91,0	125,0	83,5	118,0	77,0	90,5	-
18	103,0	125,0	94,0	110,0	78,0	85,5	88,5	125,0	82,0	112,0	76,5	86,5	-
20	101,0	125,0	92,0	104,0	74,5	82,0	86,0	118,0	80,0	106,0	74,5	83,0	-
22	99,5	120,0	90,0	99,0	71,5	78,5	84,0	111,0	78,0	101,0	72,5	79,5	-
24	95,5	114,0	85,5	94,0	68,5	75,5	81,5	104,0	76,0	96,5	69,5	76,5	-
26	89,5	106,0	81,5	90,0	65,5	72,5	79,0	97,5	74,5	92,0	67,0	74,0	-
28	83,0	98,0	78,0	86,0	63,5	69,5	77,0	90,0	73,0	88,5	64,5	71,0	-
30	76,5	90,5	75,0	82,5	61,0	67,5	74,5	83,5	71,5	83,5	62,5	69,0	-
34	67,5	77,0	69,0	76,0	57,0	63,0	69,5	71,5	68,0	73,0	58,5	64,5	-
38	61,0	66,0	62,5	66,5	53,5	59,0	63,5	60,5	62,5	63,5	55,0	60,5	-
42	54,5	55,5	56,0	56,0	50,5	56,0	56,0	51,5	56,5	55,0	52,0	55,5	-
46	48,2	47,7	49,2	48,1	47,3	48,5	48,0	44,2	48,4	46,9	48,8	47,3	-
50	41,6	41,1	42,6	41,5	42,2	41,8	41,5	38,2	41,9	40,2	42,2	40,6	-
54	35,0	35,6	36,1	36,0	37,0	36,3	36,1	33,8	36,4	34,5	36,7	34,9	-
58	30,0	30,7	30,6	31,1	32,2	31,4	31,3	29,1	31,6	29,5	31,9	29,9	-
62	26,6	26,6	27,1	26,9	28,6	27,2	27,1	25,0	27,4	25,3	27,7	25,6	-
66	23,1	23,0	23,6	23,3	25,0	23,5	23,6	21,4	23,8	21,7	24,1	22,0	-
70	19,6	19,9	20,1	20,2	21,5	20,4	20,5	18,3	20,7	18,5	20,9	18,8	-
74	16,2	17,2	16,6	17,4	17,9	17,6	17,8	15,5	18,0	15,8	18,2	16,0	-
78	12,7	14,9	13,2	15,0	14,4	15,2	15,4	13,2	15,6	13,4	15,8	13,5	-
82	9,2	12,8	9,7	12,9	10,8	13,0	13,3	11,0	13,5	11,2	13,6	11,4	-
83	8,3	12,3	8,8	12,4	9,9	12,5	12,8	10,5	13,0	10,7	13,1	10,9	-
86	5,8	10,9	6,2	11,0	-	-	11,5	9,2	11,6	9,3	11,7	9,4	-
87	4,9	10,5	5,3	10,6	-	-	11,0	8,7	11,1	8,9	11,2	9,0	-
88	-	-	-	-	-	-	10,6	8,3	10,7	8,4	10,8	8,5	-
90	-	-	-	-	-	-	9,8	7,5	9,9	7,6	-	-	-
92	-	-	-	-	-	-	9,1	6,7	9,2	6,8	-	-	-

m	96 m						102 m						
	SH/LH+LF2	SH/LH+LF2 SGLmax.	SH/LH+LF2	SH/LH+LF2 SGLmax.	SH/LH+LF2	SH/LH+LF2 SGLmax.	SH/LH+LF2	SH/LH+LF2 SGLmax.	SH/LH+LF2	SH/LH+LF2 SGLmax.	SH/LH+LF2	SH/LH+LF2 SGLmax.	
	10°		15°		20°		10°		15°		20°		
t	t	t	t	t	t	t	t	t	t	t	t	t	
15	86,5	116,0	-	-	-	-	72,5	109,0	-	-	-	-	-
16	86,5	116,0	80,0	109,0	-	-	72,5	109,0	67,0	104,0	-	-	-
17	85,5	114,5	80,0	109,0	73,5	88,0	72,5	109,0	67,0	104,0	62,0	88,5	-
18	84,5	113,0	79,0	109,0	73,5	87,5	71,5	109,0	67,0	104,0	62,0	88,5	-
20	82,5	109,0	77,0	105,0	72,0	84,0	69,5	105,0	65,5	102,0	61,5	85,0	-
22	80,5	105,0	75,5	101,0	70,5	81,0	67,5	101,0	63,5	99,0	60,0	82,0	-
24	78,5	101,0	74,0	96,5	69,5	78,0	66,0	96,5	62,0	96,0	58,5	79,0	-
26	76,5	97,0	72,0	92,5	68,0	75,0	64,0	92,5	60,5	92,5	57,5	76,5	-
28	73,0	91,0	70,0	88,0	66,0	72,5	62,5	88,0	59,0	89,5	56,0	74,0	-
30	70,0	84,5	68,0	83,0	63,5	70,0	61,0	82,0	58,0	84,5	55,0	71,5	-
34	63,5	73,5	63,5	74,0	59,5	66,0	58,0	71,0	55,5	73,5	53,0	67,0	-
38	58,0	63,0	58,5	64,5	56,0	62,0	55,0	61,5	53,0	63,5	50,5	63,5	-
42	53,0	53,5	53,5	54,0	53,0	54,5	50,5	52,5	49,3	53,0	47,5	53,5	-
46	47,2	45,6	47,7	46,1	48,1	46,6	46,6	44,4	45,4	44,9	44,0	45,4	-
50	40,7	38,9	41,1	39,4	41,5	39,8	40,0	37,4	40,4	37,9	40,4	38,4	-
54	35,1	33,0	35,5	33,5	35,9	33,9	34,3	31,5	34,7	32,0	35,1	32,5	-
58	30,3	28,1	30,6	28,5	31,0	28,9	29,4	26,6	29,8	27,0	30,2	27,4	-
62	26,1	24,0	26,4	24,3	26,7	24,6	25,2	22,4	25,6	22,8	25,9	23,1	-
66	22,6	20,4	22,8	20,7	23,1	21,0	21,7	18,7	22,0	19,1	22,3	19,4	-
67	21,8	19,6	22,0	19,9	22,3	20,2	-	17,9	-	18,3	21,4	18,6	-
70	19,5	17,2	19,7	17,5	19,9	17,8	-	15,6	-	15,9	-	16,2	-
74	16,7	14,5	17,0	14,7	17,2	15,0	-	12,8	-	13,1	-	13,4	-
78	14,4	12,1	14,6	12,3	14,7	12,5	-	10,4	-	10,7	-	10,9	-
82	12,2	9,9	12,4	10,1	12,6	10,3	-	8,3	-	8,5	-	8,7	-
86	10,4	8,0	10,5	8,2	10,7	8,4	-	6,3	-	6,5	-	6,7	-
90	8,7	6,3	8,8	6,5	8,9	6,6	-	4,6	-	4,8	-	5,0	-
92	7,9	5,5	8,0	5,7	8,1	5,8	-	3,8	-	4,0	-	4,2	-
93	7,5	5,1	7,6	5,3	7,8	5,4	-	-	-	3,6	-	3,8	-
94	7,2	4,8	7,3	5,0	-	-	-	-	-	-	-	-	-
97	6,2	3,8	6,3	3,9	-	-	-	-	-	-	-	-	-

TEREX DEMAG TC 2800-1

AUTOJEŘÁB

//Tomáš Novotný
AUTOJEŘÁBY DEMOLICE s.r.o.

SSL+LF2, SSL/LSL+LF2 WORKING RANGES · ARBEITSBEREICHE ·
PORTÉES

10°

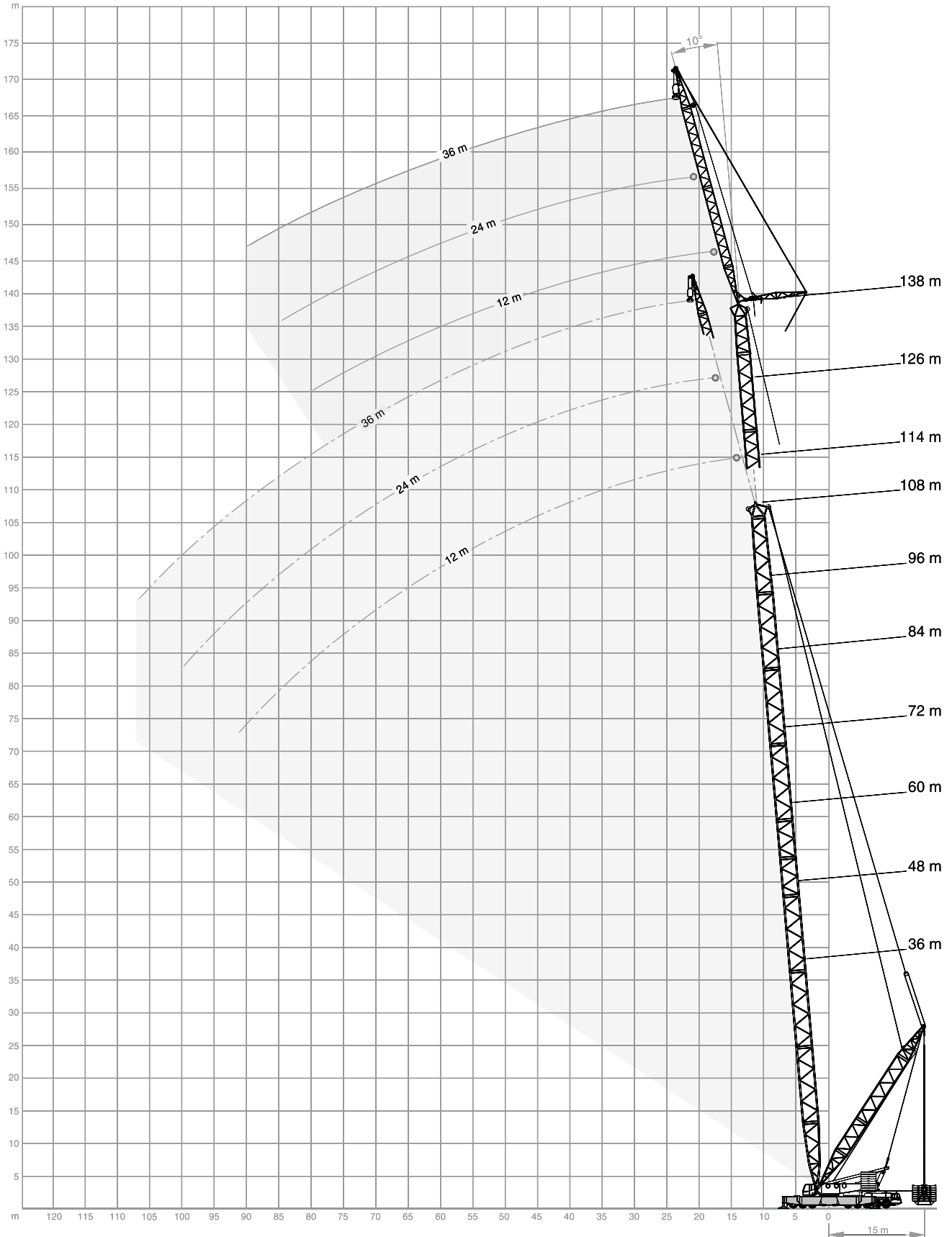

TEREX DEMAG TC 2800-1

AUTOJEŘÁB

//Tomáš Novotný
AUTOJEŘÁBY DEMOLICE s.r.o.

SSL+LF2 LIFTING CAPACITIES · TRAGFÄHIGKEITEN · CAPACITÉS DE LEVAGE

160 t 11-15 m 0-300 t 12 m 14 m x 14 m 360° DIN/ISO

m	42 m			48 m			54 m						
	SSL			SSL			SSL	HSSL	SSL	HSSL	SSL	HSSL	
	10°	15°	20°	10°	15°	20°	10°		15°		20°		
t	t	t	t	t	t	t	t	t	t	t	t	t	
10	125,0	-	-	125,0	-	-	-	-	-	-	-	-	-
11	125,0	109,0	-	125,0	112,0	-	125,0	125,0	-	-	-	-	-
12	125,0	103,0	81,5	125,0	106,0	83,5	125,0	125,0	109,0	109,0	-	-	-
13	125,0	98,0	78,5	125,0	102,0	80,5	125,0	125,0	105,0	104,5	82,0	82,0	82,0
14	120,0	93,5	75,5	125,0	97,5	77,5	125,0	125,0	100,0	100,0	79,0	79,0	79,0
16	108,0	85,5	70,0	114,0	89,5	72,0	120,0	121,0	93,0	93,0	74,0	74,0	74,0
18	98,0	79,0	65,0	104,0	83,0	67,5	110,0	110,0	86,5	86,5	70,0	70,0	70,0
20	89,5	73,5	61,0	95,5	77,0	63,5	101,0	102,0	80,5	80,5	66,0	66,0	66,0
22	82,5	68,5	57,5	88,5	72,5	60,0	94,0	94,5	76,0	76,0	62,5	62,5	62,5
24	76,5	64,0	54,5	82,5	68,0	57,0	87,5	88,0	71,5	71,5	59,5	59,5	59,5
26	71,5	60,5	51,5	77,0	64,0	54,0	82,0	82,0	67,5	67,5	56,5	56,5	56,5
28	67,0	57,0	49,4	72,0	60,5	51,5	77,0	77,5	64,0	64,0	54,0	54,0	54,0
30	63,0	54,0	47,2	68,0	57,5	49,7	72,5	73,0	61,0	61,0	52,0	52,0	52,0
34	56,5	49,5	43,4	61,0	52,5	45,8	65,5	66,0	55,5	56,0	48,0	48,2	48,2
38	51,0	45,5	40,4	55,5	48,5	42,6	59,5	59,8	51,0	51,6	44,7	44,8	44,8
42	47,2	42,2	37,9	51,0	45,0	40,0	54,5	54,5	47,8	47,8	42,0	42,0	42,0
46	43,7	39,6	36,0	47,2	42,2	37,8	50,5	50,8	44,7	44,8	39,6	39,7	39,7
48	42,3	38,6	35,2	45,6	41,0	36,9	48,8	49,0	43,4	43,3	38,6	38,6	38,6
50	41,0	37,6	-	44,1	39,8	36,1	47,2	47,4	42,1	42,2	37,7	37,7	37,7
53	-	-	-	42,1	38,3	35,0	45,1	45,1	40,5	40,5	36,5	36,5	36,5
54	-	-	-	41,5	37,9	-	44,4	44,4	40,0	40,0	36,1	36,1	36,1
55	-	-	-	41,0	37,5	-	43,8	43,8	39,5	39,5	35,8	35,8	35,8
58	-	-	-	-	-	-	42,0	42,1	38,2	38,3	34,9	34,9	34,9
60	-	-	-	-	-	-	40,9	41,0	37,5	37,5	-	-	-
61	-	-	-	-	-	-	-	-	37,2	37,2	-	-	-

m	60 m						66 m						
	SSL	HSSL	SSL	HSSL	SSL	HSSL	SSL	HSSL	SSL	HSSL	SSL	HSSL	
	10°		15°		20°		10°		15°		20°		
t	t	t	t	t	t	t	t	t	t	t	t	t	
11	125,0	125,0	-	-	-	-	-	-	-	-	-	-	-
12	125,0	125,0	112,0	112,0	-	-	125,0	125,0	-	-	-	-	-
13	125,0	125,0	107,0	107,5	83,5	83,5	125,0	125,0	110,0	110,0	-	-	-
14	125,0	125,0	103,0	103,0	80,5	80,5	125,0	125,0	106,0	106,0	82,0	82,0	82,0
16	125,0	125,0	96,0	96,0	76,0	76,0	125,0	125,0	98,5	98,5	77,5	77,5	77,5
18	115,0	116,0	89,5	89,5	71,5	71,5	120,0	121,0	92,0	92,0	73,5	73,5	73,5
20	106,0	107,0	84,0	84,0	68,0	68,0	111,0	112,0	86,5	86,5	69,5	69,5	69,5
22	99,0	99,5	79,0	79,0	64,5	64,5	104,0	104,0	82,0	82,0	66,0	66,0	66,0
24	92,5	93,0	74,5	74,5	61,5	61,5	97,0	97,5	77,5	77,5	63,0	63,0	63,0
26	86,5	87,0	70,5	70,5	58,5	58,5	91,5	91,5	73,5	73,5	60,5	60,5	60,5
28	81,5	82,0	67,0	67,0	56,0	56,0	86,0	86,5	70,0	70,0	58,0	58,0	58,0
30	77,0	77,5	64,0	64,0	54,0	54,0	81,5	81,5	67,0	67,0	55,5	55,5	55,5
34	69,5	70,1	58,5	58,6	50,0	50,2	73,5	74,1	61,0	61,6	51,5	51,8	51,8
38	63,5	63,8	54,0	54,0	46,7	46,8	67,0	67,6	56,5	56,8	48,5	48,5	48,5
42	58,0	58,5	50,0	50,0	43,8	43,8	61,5	62,0	52,5	52,5	45,6	45,6	45,6
46	54,0	54,1	47,1	47,1	41,4	41,4	57,0	57,3	49,5	49,5	43,1	43,2	43,2
50	50,0	50,4	44,4	44,4	39,3	39,4	53,0	53,3	46,6	46,7	40,9	41,0	41,0
54	47,2	47,3	42,0	42,0	37,6	37,6	50,0	50,0	44,1	44,1	39,1	39,1	39,1
58	44,6	44,7	40,1	40,1	36,1	36,2	47,2	47,3	42,0	42,0	37,5	37,5	37,5
62	42,3	42,5	38,4	38,5	35,0	34,9	44,7	44,9	40,1	40,2	36,1	36,2	36,2
63	41,8	42,0	38,0	38,1	34,7	34,7	44,1	44,3	39,7	39,8	35,8	35,9	35,9
65	40,9	41,0	37,4	37,4	-	-	43,1	43,2	38,9	39,0	35,2	35,3	35,3
66	-	-	37,1	37,1	-	-	42,6	42,7	38,6	38,6	35,0	35,0	35,0
68	-	-	-	-	-	-	41,7	41,8	37,9	38,0	34,6	34,6	34,6
70	-	-	-	-	-	-	40,8	40,9	37,3	37,4	-	-	-
71	-	-	-	-	-	-	40,4	40,5	37,1	37,1	-	-	-
74	-	-	-	-	-	-	-	-	-	-	-	-	-

Remarks · Bemerkungen · Remarques

see page 28 · siehe Seite 28 · voir page 28

TEREX DEMAG TC 2800-1

AUTOJEŘÁB

//Tomáš Novotný
AUTOJEŘÁBY DEMOLICE s.r.o.

SSL+LF2 LIFTING CAPACITIES · TRAGFÄHIGKEITEN · CAPACITÉS DE LEVAGE

160 t 11-15 m 0-300 t 12 m 14 m x 14 m 360° DIN/ISO

m	72 m						78 m					
	SSL		HSSL		SSL		HSSL		SSL		HSSL	
	10°	15°	15°	20°	20°	20°	10°	15°	15°	20°	20°	
t	t	t	t	t	t	t	t	t	t	t	t	
12	125,0	125,0	-	-	-	-	-	-	-	-	-	-
13	125,0	125,0	112,0	112,0	-	-	125,0	125,0	-	-	-	-
14	125,0	125,0	108,0	108,0	83,0	83,0	125,0	125,0	110,0	110,0	-	-
15	125,0	125,0	104,0	104,5	81,0	80,7	125,0	125,0	106,0	106,5	82,0	82,0
16	125,0	125,0	101,0	101,0	78,5	78,5	125,0	125,0	103,0	103,0	80,0	80,0
18	125,0	124,0	95,0	95,0	74,5	74,5	125,0	124,0	97,0	97,0	76,0	76,0
20	116,0	116,0	89,5	89,5	71,0	71,0	120,0	121,0	91,5	91,5	72,5	72,5
22	108,0	109,0	84,5	84,5	68,0	68,0	112,0	113,0	87,0	87,0	69,5	69,5
24	101,0	102,0	80,0	80,0	65,0	65,0	105,0	106,0	82,5	82,5	66,5	66,5
26	95,5	96,0	76,0	76,0	62,0	62,0	99,5	100,0	78,5	78,5	63,5	63,5
28	90,0	90,5	72,5	72,5	59,5	59,5	94,0	94,5	75,0	75,0	61,5	61,5
30	85,5	85,5	69,5	69,5	57,5	57,5	89,5	89,5	72,0	72,0	59,0	59,0
34	77,5	77,8	63,5	64,1	53,5	53,5	81,0	81,5	66,0	66,3	55,0	55,0
38	70,5	71,0	59,0	59,3	50,0	50,0	74,0	74,5	61,5	61,3	51,5	51,6
42	65,0	65,0	55,0	55,0	47,2	47,2	68,0	68,5	57,0	57,0	48,8	48,8
46	60,0	60,3	51,5	51,6	44,7	44,7	63,0	63,5	53,5	53,6	46,2	46,2
50	56,0	56,1	48,7	48,7	42,4	42,5	59,0	59,1	50,5	50,6	43,9	43,9
54	52,5	52,5	46,1	46,1	40,5	40,5	55,5	55,5	48,0	48,0	41,9	41,9
58	49,8	49,8	43,8	43,9	38,8	38,8	52,0	52,5	45,7	45,7	40,1	40,1
62	47,1	47,3	41,9	41,9	37,3	37,3	49,5	49,7	43,6	43,6	38,6	38,6
66	44,8	44,9	40,2	40,2	36,1	36,1	47,1	47,2	41,8	41,8	37,2	37,2
70	42,9	42,9	38,7	38,8	35,1	35,1	44,9	45,0	40,2	40,2	36,1	36,1
73	41,6	41,6	37,8	37,8	34,5	34,5	43,5	43,5	39,1	39,2	35,3	35,3
74	41,2	41,2	37,5	37,5	-	-	43,1	43,1	38,8	38,9	35,1	35,1
76	40,4	40,5	37,0	37,0	-	-	42,2	42,3	38,2	38,3	34,7	34,7
78	-	-	-	-	-	-	41,4	41,5	37,7	37,7	34,3	34,3
81	-	-	-	-	-	-	40,4	40,4	36,9	36,9	-	-

Remarks · Bemerkungen · Remarques

SSL+LF2:

Max. capacities with minimum counterweight · Maximale Tragfähigkeiten bei Mindestgegengewicht · Capacités maximales avec contrepoids minimum.

For HSSL+LF2 a boom power-kit is required

Für HSSL+LF2 ist ein Ausleger-Verstärkungs-Kit erforderlich

Un kit à fortifier de flèche principale est nécessaire pour HSSL+LF2

TEREX DEMAG TC 2800-1

AUTOJEŘÁB

//Tomáš Novotný
AUTOJEŘÁBY DEMOLICE s.r.o.

SSL+LF2 LIFTING CAPACITIES · TRAGFÄHIGKEITEN · CAPACITÉS DE LEVAGE

160 t 11-15 m 0-300 t 12 m 14 m x 14 m 360° DIN/ISO

m	84 m						90 m			96 m		
	SSL		HSSL		SSL		HSSL		HSSL		HSSL	
	10°		15°		20°		10°	15°	20°	10°	15°	20°
	t	t	t	t	t	t	t	t	t	t	t	t
13	125,0	125,0	-	-	-	-	-	-	-	-	-	-
14	125,0	125,0	112,0	112,0	-	-	125,0	125,0	-	-	-	-
15	125,0	125,0	108,0	108,5	83,0	83,0	125,0	125,0	110,0	111,0	-	-
16	125,0	125,0	105,0	105,0	81,0	81,0	125,0	125,0	107,0	108,0	82,5	82,5
18	125,0	125,0	99,0	99,0	77,0	77,0	125,0	125,0	101,0	103,0	79,0	79,0
20	124,0	123,0	94,0	94,0	74,0	74,0	124,0	124,0	96,0	97,5	76,0	76,0
22	116,0	117,0	89,0	89,0	70,5	70,5	121,0	121,0	91,0	93,0	73,0	73,0
24	109,0	110,0	85,0	85,0	68,0	68,0	114,0	114,0	87,0	89,0	70,0	70,0
26	103,0	104,0	81,0	81,0	65,0	65,0	107,0	107,0	83,0	85,0	67,5	67,5
28	98,0	98,5	77,5	77,5	62,5	62,5	102,0	102,0	79,5	81,5	65,5	65,5
30	93,0	93,5	74,0	74,0	60,5	60,5	97,0	97,0	76,0	78,0	63,0	63,0
34	84,5	85,1	68,5	68,6	56,5	56,5	88,3	88,3	70,6	72,6	59,3	59,3
38	77,5	77,8	63,5	63,8	53,0	53,0	80,8	80,8	65,8	67,6	55,8	55,8
42	71,5	71,5	59,5	59,5	50,0	50,0	74,5	74,5	61,5	63,0	52,5	52,5
46	66,0	66,5	55,5	55,8	47,6	47,6	69,5	69,5	57,8	59,6	50,1	50,1
50	62,0	62,0	52,5	52,6	45,3	45,3	64,8	64,8	54,5	56,3	47,9	47,9
54	58,0	58,0	49,9	49,9	43,2	43,2	60,5	60,5	51,5	53,0	45,7	45,7
58	54,5	54,6	47,4	47,5	41,4	41,4	57,1	57,1	49,1	50,7	43,8	43,8
62	51,5	51,8	45,3	45,3	39,8	39,7	54,1	54,1	46,9	48,5	42,1	42,1
66	49,3	49,4	43,4	43,4	38,3	38,3	51,5	51,5	44,9	46,4	40,5	40,5
70	47,0	47,2	41,7	41,7	37,1	37,1	49,2	49,2	43,1	44,6	39,1	39,1
74	45,0	45,1	40,2	40,2	36,0	36,0	47,1	47,1	41,5	42,9	37,9	37,9
78	43,2	43,3	38,9	38,9	35,1	35,1	45,1	45,1	40,1	41,4	36,8	36,8
82	41,7	41,0	37,8	37,8	34,4	34,3	42,1	42,1	38,9	39,6	35,9	35,9
83	41,2	40,4	37,5	37,5	34,2	34,2	41,3	41,3	38,6	39,2	35,7	35,7
86	39,7	38,3	36,9	36,9	-	-	38,9	38,9	37,2	36,9	34,4	34,4
87	-	-	36,7	36,7	-	-	38,0	38,0	36,6	36,1	33,8	33,8
90	-	-	-	-	-	-	35,5	35,5	34,8	33,9	32,2	32,2
91	-	-	-	-	-	-	34,6	34,6	34,2	33,1	31,6	31,6
92	-	-	-	-	-	-	-	-	33,7	32,3	31,1	31,1
94	-	-	-	-	-	-	-	-	-	30,8	-	-
97	-	-	-	-	-	-	-	-	-	28,6	-	-
98	-	-	-	-	-	-	-	-	-	-	-	-

3

Remarks · Bemerkungen · Remarques

SSL+LF2:

Max. capacities with minimum counterweight · Maximale Tragfähigkeiten bei Mindestgegengewicht · Capacités maximales avec contrepoids minimum.

For HSSL+LF2 a boom power-kit is required

Für HSSL+LF2 ist ein Ausleger-Verstärkungs-Kit erforderlich

Un kit à fortifier de flèche principale est nécessaire pour HSSL+LF2

TEREX DEMAG TC 2800-1

AUTOJEŘÁB

//Tomáš Novotný
AUTOJEŘÁBY DEMOLICE s.r.o.

SSL+LF2 LIFTING CAPACITIES · TRAGFÄHIGKEITEN · CAPACITÉS DE LEVAGE

160 t 11-15 m 0-300 t 12 m 14 m x 14 m 360° DIN/ISO

m	102 m			108 m		
	HSSL			HSSL		
	10°	15°	20°	10°	15°	20°
15	t	t	-	-	-	-
16	125,0	125,0	110,0	111,0	-	-
17	125,0	125,0	107,0	108,5	82,5	82,5
18	125,0	125,0	104,0	106,0	81,0	81,0
20	125,0	125,0	99,5	101,0	77,5	77,5
22	125,0	125,0	95,0	96,5	75,0	75,0
24	120,0	120,0	90,5	92,5	72,0	72,0
26	114,0	114,0	87,0	88,5	70,0	70,0
28	108,0	108,0	83,5	85,0	67,5	67,5
30	103,0	103,0	80,0	82,0	65,5	65,5
34	94,6	94,6	74,3	76,3	61,5	61,5
38	87,1	87,1	69,3	71,1	58,0	58,0
42	80,5	80,5	65,0	66,5	55,0	55,0
46	74,8	74,8	61,3	62,8	52,3	52,3
50	69,8	69,8	58,0	59,5	49,9	49,9
54	65,5	65,5	55,0	56,5	47,9	47,9
58	61,8	61,8	52,3	53,8	45,9	45,9
62	58,5	58,5	49,9	51,4	44,2	44,2
66	55,5	55,5	47,9	49,4	42,6	42,6
70	53,1	53,1	46,0	47,4	41,1	41,1
74	50,8	50,8	44,3	45,6	39,8	39,8
78	48,5	48,5	42,7	44,0	38,6	38,6
82	44,7	44,7	41,3	42,5	37,5	37,5
86	40,8	40,8	38,3	40,0	35,7	35,7
90	37,0	37,0	35,1	36,6	33,2	33,2
94	33,1	33,1	31,9	33,1	30,4	30,4
98	29,3	29,3	28,6	29,6	27,7	27,7
102	25,5	25,5	25,4	26,2	24,9	24,9
106	-	-	-	22,6	-	-
107	-	-	-	21,8	-	-
110	-	-	-	-	-	-

Remarks · Bemerkungen · Remarques

SSL+LF2:

Max. capacities with minimum counterweight · Maximale Tragfähigkeiten bei Mindestgegengewicht · Capacités maximales avec contrepoids minimum.

For HSSL+LF2 a boom power-kit is required

Für HSSL+LF2 ist ein Ausleger-Verstärkungs-Kit erforderlich

Un kit à fortifier de flèche principale est nécessaire pour HSSL+LF2

SSL/LSL+LF2 LIFTING CAPACITIES · TRAGFÄHIGKEITEN · CAPACITÉS DE LEVAGE

160 t 11-15 m 0-300 t 12 m 14 m x 14 m 360° DIN/ISO

m	90 m						96 m						
	SSL/LSL+LF2		SSL/LSL+LF2 SGLmax.		SSL/LSL+LF2		SSL/LSL+LF2 SGLmax.		SSL/LSL+LF2		SSL/LSL+LF2 SGLmax.		
	10°	15°	15°	20°	20°	10°	15°	15°	20°	20°	10°	15°	
t	t	t	t	t	t	t	t	t	t	t	t	t	t
14	125,0	125,0	-	-	-	-	-	-	-	-	-	-	-
15	125,0	125,0	111,0	122,0	-	-	125,0	125,0	-	-	-	-	-
16	125,0	125,0	108,0	118,0	82,5	90,5	125,0	125,0	109,0	120,0	-	-	-
17	125,0	125,0	105,0	115,0	80,7	88,5	124,0	125,0	106,5	117,0	81,5	89,5	-
18	125,0	125,0	102,0	112,0	79,0	86,5	123,0	125,0	104,0	114,0	80,0	87,5	-
20	125,0	125,0	97,0	106,0	75,5	83,0	121,0	125,0	98,5	108,0	76,5	84,0	-
22	121,0	125,0	92,0	101,0	72,5	79,5	119,0	125,0	94,0	103,0	73,5	81,0	-
24	114,0	120,0	88,0	96,5	69,5	76,5	117,0	123,0	89,5	98,5	71,0	78,0	-
26	107,0	113,0	84,0	92,0	67,0	74,0	111,0	117,0	86,0	94,5	68,0	75,0	-
28	102,0	107,0	80,5	88,5	64,5	71,0	105,0	111,0	82,5	90,5	66,0	72,5	-
30	97,0	102,0	77,0	84,5	62,5	69,0	100,0	105,0	79,0	87,0	63,5	70,0	-
34	88,6	93,6	71,3	78,5	58,5	64,6	91,6	96,6	73,3	81,0	59,8	66,0	-
38	81,3	86,0	66,3	73,1	55,0	60,8	84,1	89,0	68,3	75,5	56,3	62,1	-
42	75,0	79,0	62,0	68,5	52,0	57,5	77,5	82,0	64,0	70,5	53,0	58,5	-
46	69,6	73,6	58,3	64,5	49,4	54,5	72,5	76,6	60,3	66,5	50,6	55,8	-
50	65,0	68,8	55,0	60,8	47,0	51,8	67,8	71,8	57,0	62,8	48,2	53,1	-
54	61,0	64,5	52,0	57,5	44,8	49,6	63,5	67,5	54,0	59,5	46,0	50,5	-
58	57,6	61,1	49,6	54,8	43,0	47,6	59,8	63,8	51,3	56,5	44,1	48,7	-
62	54,5	58,0	47,4	52,3	41,3	45,7	56,6	60,3	48,9	53,8	42,4	47,0	-
66	51,5	55,0	45,3	50,0	39,8	44,1	54,0	57,0	46,9	51,5	40,8	45,3	-
70	49,4	52,3	43,5	48,2	38,4	42,7	51,3	54,6	45,0	49,7	39,4	43,8	-
74	47,4	50,0	41,9	46,5	37,2	41,4	49,0	52,3	43,3	48,0	38,2	42,4	-
78	45,4	48,2	40,5	44,9	36,2	40,2	47,2	50,0	41,8	46,3	37,1	41,2	-
82	43,7	45,2	39,3	43,1	35,4	39,2	45,3	46,8	40,5	44,1	36,1	40,2	-
86	41,6	42,1	38,2	40,9	34,6	38,4	42,8	43,4	39,1	41,5	35,3	38,7	-
88	40,3	40,4	37,7	39,5	34,3	38,1	41,2	41,6	38,3	40,0	34,9	37,7	-
90	39,1	38,7	37,3	38,2	-	-	39,6	39,7	37,6	38,5	34,6	36,6	-
92	37,5	-	36,9	-	-	-	38,0	37,9	36,4	37,0	34,3	35,5	-
93	-	-	-	-	-	-	37,2	37,0	35,9	36,2	34,2	35,0	-
94	-	-	-	-	-	-	36,4	36,1	35,3	35,5	-	-	-
97	-	-	-	-	-	-	34,0	-	33,7	-	-	-	-

3

Remarks · Bemerkungen · Remarques

SSL/LSL+LF2:

Max. capacities with minimum counterweight · Maximale Tragfähigkeiten bei Mindestgegengewicht · Capacités maximales avec contrepoids minimum.

For SSL/LSL+LF2 SGLmax. a boom power-kit is required

Für SSL/LSL+LF2 SGLmax. ist ein Ausleger-Verstärkungs-Kit erforderlich

Un kit à fortifier de flèche principale est nécessaire pour SSL/LSL+LF2 SGLmax.

TEREX DEMAG TC 2800-1

AUTOJEŘÁB

//Tomáš Novotný
AUTOJEŘÁBY DEMOLICE s.r.o.

SSL/LSL+LF2 LIFTING CAPACITIES · TRAGFÄHIGKEITEN · CAPACITÉS DE LEVAGE

160 t 11-15 m 0-300 t 12 m 14 m x 14 m 360° DIN/ISO

m	102 m						108 m					
	SSL/LSL+LF2		SSL/LSL+LF2 SGLmax.		SSL/LSL+LF2		SSL/LSL+LF2 SGLmax.		SSL/LSL+LF2		SSL/LSL+LF2 SGLmax.	
	10°		15°		20°		10°		15°		20°	
t	t	t	t	t	t	t	t	t	t	t	t	t
15	109,0	125,0	-	-	-	-	-	-	-	-	-	-
16	109,0	125,0	99,0	122,0	-	-	94,5	124,0	-	-	-	-
17	108,0	125,0	98,5	118,5	81,5	90,5	94,0	124,0	87,0	120,0	-	-
18	107,0	125,0	98,0	115,0	80,5	88,5	93,5	124,0	87,0	117,0	79,5	89,5
20	105,0	125,0	96,0	110,0	77,5	85,0	91,5	123,0	85,0	112,0	78,5	86,0
22	103,0	125,0	94,0	105,0	74,5	82,0	89,5	122,0	83,0	107,0	75,5	83,0
24	101,0	125,0	91,5	100,0	72,0	79,0	87,0	121,0	81,0	102,0	73,0	80,0
26	99,0	120,0	87,5	96,5	69,5	76,5	84,5	120,0	78,5	98,5	70,5	77,5
28	96,5	114,0	84,0	92,5	67,0	74,0	82,0	117,0	76,5	94,5	68,0	75,0
30	94,0	109,0	81,0	89,0	65,0	71,5	80,0	112,0	74,5	91,0	66,0	72,5
34	89,3	100,0	75,3	83,0	61,0	67,1	75,3	103,0	70,5	85,0	62,0	68,5
38	84,8	92,0	70,1	77,5	57,5	63,3	71,3	95,0	67,0	79,5	58,5	64,8
42	80,5	85,0	65,5	72,5	54,5	60,0	68,0	88,0	64,0	74,5	55,5	61,5
46	75,1	79,3	61,8	68,5	51,8	57,0	64,6	82,3	61,3	70,1	52,8	58,5
50	70,3	74,3	58,5	64,6	49,4	54,3	61,5	77,0	58,6	66,3	50,4	55,6
54	66,0	70,0	55,5	61,0	47,2	52,0	58,5	72,0	56,0	63,0	48,3	53,0
58	62,3	66,0	52,8	58,3	45,2	50,0	55,5	68,0	53,3	60,0	46,3	51,0
62	59,0	62,5	50,4	55,8	43,5	48,2	52,6	64,5	50,7	57,3	44,5	49,1
66	56,0	59,5	48,4	53,5	41,9	46,4	49,8	61,5	48,3	55,0	42,9	47,5
70	53,3	56,8	46,4	51,1	40,5	44,8	47,1	58,8	45,9	52,6	41,4	45,9
74	51,0	54,3	44,7	49,2	39,2	43,4	44,6	55,6	43,6	50,7	40,1	44,5
78	49,0	52,0	43,1	47,7	38,0	42,2	42,2	52,0	41,6	49,2	38,9	43,2
82	45,8	48,8	41,1	45,3	37,0	40,8	39,8	48,4	39,4	46,4	37,8	41,4
86	42,4	45,1	38,8	42,5	36,0	38,8	37,5	44,8	37,3	43,0	36,6	38,8
90	39,0	41,3	36,2	39,2	34,7	36,4	35,2	41,1	35,3	39,6	34,7	36,2
94	35,5	37,3	33,6	35,9	32,9	33,9	32,8	37,3	33,2	36,2	32,7	33,5
98	32,0	33,4	30,9	32,6	31,2	31,5	30,4	33,6	31,1	32,8	30,8	30,9
102	28,6	29,5	28,3	29,4	-	-	28,1	29,9	29,1	29,4	28,9	28,2
103	-	-	-	-	-	-	27,5	28,9	28,6	28,5	28,4	27,5
106	-	-	-	-	-	-	25,7	26,1	27,0	26,1	-	-
107	-	-	-	-	-	-	25,2	-	26,5	-	-	-
108	-	-	-	-	-	-	-	-	26,0	-	-	-
110	-	-	-	-	-	-	-	-	-	-	-	-

Remarks · Bemerkungen · Remarques

SSL/LSL+LF2:

Max. capacities with minimum counterweight · Maximale Tragfähigkeiten bei Mindestgegengewicht · Capacités maximales avec contrepoids minimum.

For SSL/LSL+LF2 SGLmax. a boom power-kit is required

Für SSL/LSL+LF2 SGLmax. ist ein Ausleger-Verstärkungs-Kit erforderlich

Un kit à fortifier de flèche principale est nécessaire pour SSL/LSL+LF2 SGLmax.

SSL/LSL+LF2 LIFTING CAPACITIES · TRAGFÄHIGKEITEN · CAPACITÉS DE LEVAGE

160 t 11-15 m 0-300 t 12 m 14 m x 14 m 360° DIN/ISO

m	114 m						120 m					
	SSL/LSL+LF2		SSL/LSL+LF2 SGLmax.		SSL/LSL+LF2		SSL/LSL+LF2 SGLmax.		SSL/LSL+LF2		SSL/LSL+LF2 SGLmax.	
	10°	t	15°	t	20°	t	10°	t	15°	t	20°	t
16	85,5	t	115,0	-	t	-	-	t	-	-	-	-
17	85,2	115,0	79,5	111,0	-	-	75,5	107,0	-	-	-	-
18	85,0	115,0	79,5	111,0	73,5	90,5	75,5	107,0	70,0	105,0	-	-
19	84,5	115,0	79,2	110,5	73,5	88,7	75,0	107,0	69,7	104,5	65,0	89,5
20	84,0	115,0	79,0	110,0	73,5	87,0	74,5	107,0	69,5	104,0	65,0	88,0
22	82,5	115,0	77,5	108,0	72,5	84,0	73,5	107,0	68,5	103,0	64,0	85,0
24	81,0	115,0	76,5	104,0	71,5	81,0	72,5	107,0	67,5	101,0	63,5	82,0
26	79,5	115,0	75,0	100,0	70,5	78,5	71,0	107,0	66,5	100,0	62,5	79,5
28	78,0	115,0	73,5	96,5	69,0	76,0	70,0	107,0	65,5	98,0	61,5	77,0
30	76,5	113,0	72,5	92,5	67,0	73,5	68,5	107,0	64,5	94,5	60,5	74,5
34	73,5	105,0	69,5	86,5	63,0	69,5	65,8	103,0	61,8	88,5	58,1	70,5
38	70,5	97,5	66,6	81,0	59,5	65,8	63,1	98,3	59,3	83,0	56,0	66,8
42	67,5	90,5	64,0	76,0	56,5	62,5	60,5	93,0	57,0	78,0	54,0	63,5
46	64,8	84,8	61,6	72,0	53,8	59,5	58,5	87,3	55,3	73,6	52,3	60,5
50	62,3	79,5	59,5	68,1	51,4	56,8	56,5	82,0	53,5	69,8	50,7	57,8
54	60,0	74,5	57,5	64,5	49,3	54,5	54,5	77,0	51,5	66,5	49,3	55,5
58	57,3	70,8	55,1	61,8	47,3	52,1	52,5	71,6	49,8	63,5	47,7	53,5
62	54,6	66,8	52,8	59,1	45,5	50,2	50,4	66,5	48,1	60,3	46,1	51,5
66	52,0	62,5	50,5	56,5	43,9	48,6	48,4	61,5	46,3	57,0	44,5	49,6
70	49,6	57,8	48,3	54,1	42,4	47,0	46,3	56,5	44,4	54,0	42,8	48,0
74	47,2	53,8	46,1	52,2	41,0	45,5	44,2	51,9	42,5	51,3	41,1	46,4
78	44,7	50,5	43,7	50,5	39,8	44,1	42,1	47,8	40,6	48,6	39,5	45,1
82	42,2	47,1	41,3	47,3	38,6	42,5	39,8	43,6	38,6	45,4	37,5	43,8
86	39,7	43,7	38,9	43,9	37,3	40,3	37,6	39,7	36,5	42,3	35,6	41,7
90	37,2	40,3	36,5	40,5	35,8	37,4	35,4	35,9	34,5	39,1	33,7	38,9
94	34,6	36,8	34,1	37,0	33,5	34,5	33,2	32,4	32,4	35,9	31,7	35,8
98	32,1	33,3	31,7	33,6	31,2	31,5	31,0	29,1	30,3	32,7	29,8	32,6
102	29,7	29,9	29,3	30,2	29,0	28,6	28,8	26,1	28,3	29,6	27,9	29,5
106	27,1	26,4	26,9	26,7	26,7	25,6	26,6	23,3	26,2	26,4	25,9	26,3
108	25,9	24,7	25,7	25,0	25,6	24,2	25,5	21,9	25,2	24,8	25,0	24,8
110	24,6	23,0	24,5	23,3	-	-	24,4	20,6	24,1	23,2	24,0	23,2
112	23,4	-	23,3	-	-	-	23,3	19,4	23,1	21,6	23,0	21,7
113	22,8	-	22,7	-	-	-	22,7	18,8	22,6	20,8	-	-
114	-	-	-	-	-	-	22,2	18,2	22,1	20,1	-	-
118	-	-	-	-	-	-	20,0	16,1	20,1	16,9	-	-

3

Remarks · Bemerkungen · Remarques

SSL/LSL+LF2:

Max. capacities with minimum counterweight · Maximale Tragfähigkeiten bei Mindestgegengewicht · Capacités maximales avec contrepoids minimum.

For SSL/LSL+LF2 SGLmax. a boom power-kit is required

Für SSL/LSL+LF2 SGLmax. ist ein Ausleger-Verstärkungs-Kit erforderlich

Un kit à fortifier de flèche principale est nécessaire pour SSL/LSL+LF2 SGLmax.

SSL/LSL+LF2 LIFTING CAPACITIES · TRAGFÄHIGKEITEN · CAPACITÉS DE LEVAGE

160 t 11-15 m 0-300 t 12 m 14 m x 14 m 360° DIN/ISO

m	126 m						132 m					
	SSL/LSL+LF2		SSL/LSL+LF2 SGLmax.		SSL/LSL+LF2		SSL/LSL+LF2 SGLmax.		SSL/LSL+LF2		SSL/LSL+LF2 SGLmax.	
	10°	t	15°	t	20°	t	10°	t	15°	t	20°	t
17	66,0	t	97,5	t	-	-	-	-	-	-	-	-
18	66,0	66,0	97,5	62,0	96,5	-	61,5	90,5	-	-	-	-
19	65,7	65,7	97,5	62,0	96,5	58,0	61,2	90,5	58,0	89,5	-	-
20	65,5	65,5	97,5	62,0	96,5	58,0	61,0	90,5	58,0	89,5	54,5	86,5
22	64,5	64,5	97,5	61,0	96,0	57,5	60,5	90,0	57,5	89,5	54,5	86,5
24	63,5	63,5	97,5	60,0	96,0	56,5	60,0	90,0	57,0	89,0	54,0	83,5
26	62,5	62,5	97,5	59,0	95,5	55,5	59,0	89,5	56,0	89,0	53,0	81,0
28	61,5	61,5	97,5	58,0	95,0	55,0	58,5	89,5	55,5	89,0	52,5	79,0
30	60,5	60,5	97,5	57,0	95,0	54,0	57,5	89,0	54,5	88,5	52,0	76,5
34	58,1	58,1	95,8	55,0	89,6	52,0	55,8	87,6	53,1	87,5	50,6	72,5
38	55,8	55,8	93,8	53,0	84,5	50,2	54,1	86,0	51,6	85,0	49,3	68,8
42	53,5	53,5	91,5	51,0	79,5	48,6	52,5	84,0	50,0	81,0	47,9	65,5
46	51,5	51,5	86,8	49,4	75,5	47,0	51,1	80,6	48,7	77,0	46,5	62,8
50	49,7	49,7	81,5	47,8	71,6	45,5	49,7	76,5	47,4	73,1	45,3	60,1
54	48,1	48,1	75,5	46,2	68,0	44,1	48,3	71,5	46,1	69,5	44,1	57,5
58	46,3	46,3	70,1	44,6	65,0	42,6	46,8	66,5	44,7	65,8	42,9	55,5
62	44,5	44,5	65,0	43,0	61,6	41,2	45,3	61,6	43,4	61,6	41,7	53,5
66	42,7	42,7	60,0	41,4	58,0	39,8	43,8	57,0	42,1	57,0	40,5	51,5
70	40,9	40,9	54,8	39,8	54,0	38,4	42,3	52,3	40,7	52,7	39,3	49,2
74	39,1	39,1	50,4	38,2	50,1	36,9	40,8	48,0	39,4	48,5	38,1	46,5
78	37,4	37,4	46,2	36,6	46,4	35,5	39,4	44,2	38,1	44,6	36,9	43,6
82	35,5	35,5	42,1	34,9	42,8	33,9	37,9	40,4	36,7	40,8	35,6	40,8
86	33,7	33,7	38,1	33,1	39,3	32,2	36,4	36,7	35,4	37,1	34,4	38,0
90	31,9	31,9	34,4	31,4	35,9	30,6	35,0	33,1	34,1	33,5	33,2	35,3
94	30,1	30,1	31,0	29,6	32,7	28,9	33,5	29,7	32,7	30,2	32,0	32,6
98	28,3	28,3	27,7	27,8	29,5	27,2	32,0	26,6	31,4	27,0	30,8	29,9
102	26,4	26,4	24,6	26,1	26,5	25,6	30,5	23,6	30,1	24,0	29,6	27,2
106	24,6	24,6	21,8	24,3	23,7	23,9	29,0	20,8	28,7	21,2	28,4	24,5
110	22,8	22,8	19,2	22,5	20,9	22,2	27,5	18,2	27,4	18,6	27,2	21,8
114	21,0	21,0	16,8	20,8	18,3	20,5	26,1	15,8	26,2	16,1	26,0	19,1
117	19,6	19,6	15,2	19,4	16,4	19,3	25,0	14,1	25,2	14,4	25,1	17,1
118	19,2	19,2	14,7	19,0	15,7	-	24,6	13,5	24,8	13,8	24,8	16,4
122	17,3	17,3	12,8	17,2	13,4	-	22,8	11,4	23,0	11,7	23,3	13,7
123	16,9	16,9	-	16,8	-	-	22,2	10,9	22,5	11,2	-	-
126	-	-	-	-	-	-	20,6	9,5	20,8	9,7	-	-
128	-	-	-	-	-	-	19,4	-	19,6	-	-	-
130	-	-	-	-	-	-	-	-	-	-	-	-

Remarks · Bemerkungen · Remarques

SSL/LSL+LF2:

Max. capacities with minimum counterweight · Maximale Tragfähigkeiten bei Mindestgegengewicht · Capacités maximales avec contrepoids minimum.

For SSL/LSL+LF2 SGLmax. a boom power-kit is required

Für SSL/LSL+LF2 SGLmax. ist ein Ausleger-Verstärkungs-Kit erforderlich

Un kit à fortifier de flèche principale est nécessaire pour SSL/LSL+LF2 SGLmax.

TEREX DEMAG TC 2800-1

AUTOJEŘÁB

//Tomáš Novotný
AUTOJEŘÁBY DEMOLICE s.r.o.

SSL/LSL+LF2 LIFTING CAPACITIES · TRAGFÄHIGKEITEN · CAPACITÉS DE LEVAGE

160 t 11-15 m 0-300 t 12 m 14 m x 14 m 360° DIN/ISO

m	138 m					
	SSL/LSL+LF2		SSL/LSL+LF2		SSL/LSL+LF2	
	LF2	SGLmax.	LF2	SGLmax.	LF2	SGLmax.
	10°		15°		20°	
t	t	t	t	t	t	
18	53,0	79,5	-	-	-	-
19	53,0	79,5	51,5	79,0	-	-
20	53,0	79,5	51,5	79,0	49,2	78,0
22	52,5	79,0	51,5	79,0	49,2	78,0
24	52,0	78,5	51,0	78,5	48,8	77,5
26	51,5	78,0	50,5	78,0	48,4	77,0
28	51,0	77,5	50,0	77,5	48,0	77,0
30	50,0	77,0	49,7	77,0	47,6	76,5
34	49,1	76,0	48,7	76,0	46,6	73,1
38	48,1	75,0	47,6	75,0	45,7	69,8
42	46,9	74,0	46,6	74,0	44,8	66,5
46	45,3	72,3	45,4	72,6	43,8	63,5
50	43,2	69,3	43,7	69,8	42,6	60,8
54	40,8	65,0	41,7	65,5	41,3	58,5
58	38,3	60,6	39,7	61,1	39,9	56,1
62	35,8	56,5	37,6	57,0	38,6	54,0
66	33,3	52,5	35,6	53,0	37,2	51,5
70	30,8	48,8	33,6	49,2	35,8	48,1
74	28,3	45,1	31,6	45,5	34,5	44,8
78	25,9	41,5	29,5	41,9	33,2	41,6
82	23,4	38,0	27,5	38,4	31,8	38,4
84	22,2	36,3	26,5	36,7	31,2	36,9
86	-	34,6	25,4	35,0	30,5	35,3
90	-	31,4	23,4	31,8	29,1	32,3
94	-	28,3	21,4	28,7	27,8	29,4
98	-	25,3	19,3	25,7	26,4	26,6
102	-	22,5	17,3	22,8	25,1	23,9
106	-	19,8	15,3	20,1	23,7	21,2
110	-	17,2	13,2	17,5	22,3	18,6
114	-	14,8	11,2	15,1	21,0	16,2
118	-	12,6	9,1	12,8	19,6	13,8
122	-	10,4	7,1	10,6	18,2	11,5
126	-	8,4	5,1	8,6	16,9	9,3
127	-	7,9	4,5	8,1	16,6	8,8
129	-	6,9	3,5	7,2	-	-
130	-	6,5	-	6,7	-	-
134	-	-	-	4,9	-	-

3

Remarks · Bemerkungen · Remarques

SSL/LSL+LF2:

Max. capacities with minimum counterweight · Maximale Tragfähigkeiten bei Mindestgegengewicht · Capacités maximales avec contrepoids minimum.

For SSL/LSL+LF2 SGLmax. a boom power-kit is required

Für SSL/LSL+LF2 SGLmax. ist ein Ausleger-Verstärkungs-Kit erforderlich

Un kit à fortifier de flèche principale est nécessaire pour SSL/LSL+LF2 SGLmax.

TEREX DEMAG TC 2800-1

AUTOJEŘÁB

//Tomáš Novotný
AUTOJEŘÁBY DEMOLICE s.r.o.

SW WORKING RANGES · ARBEITSBEREICHE ·
PORTÉES

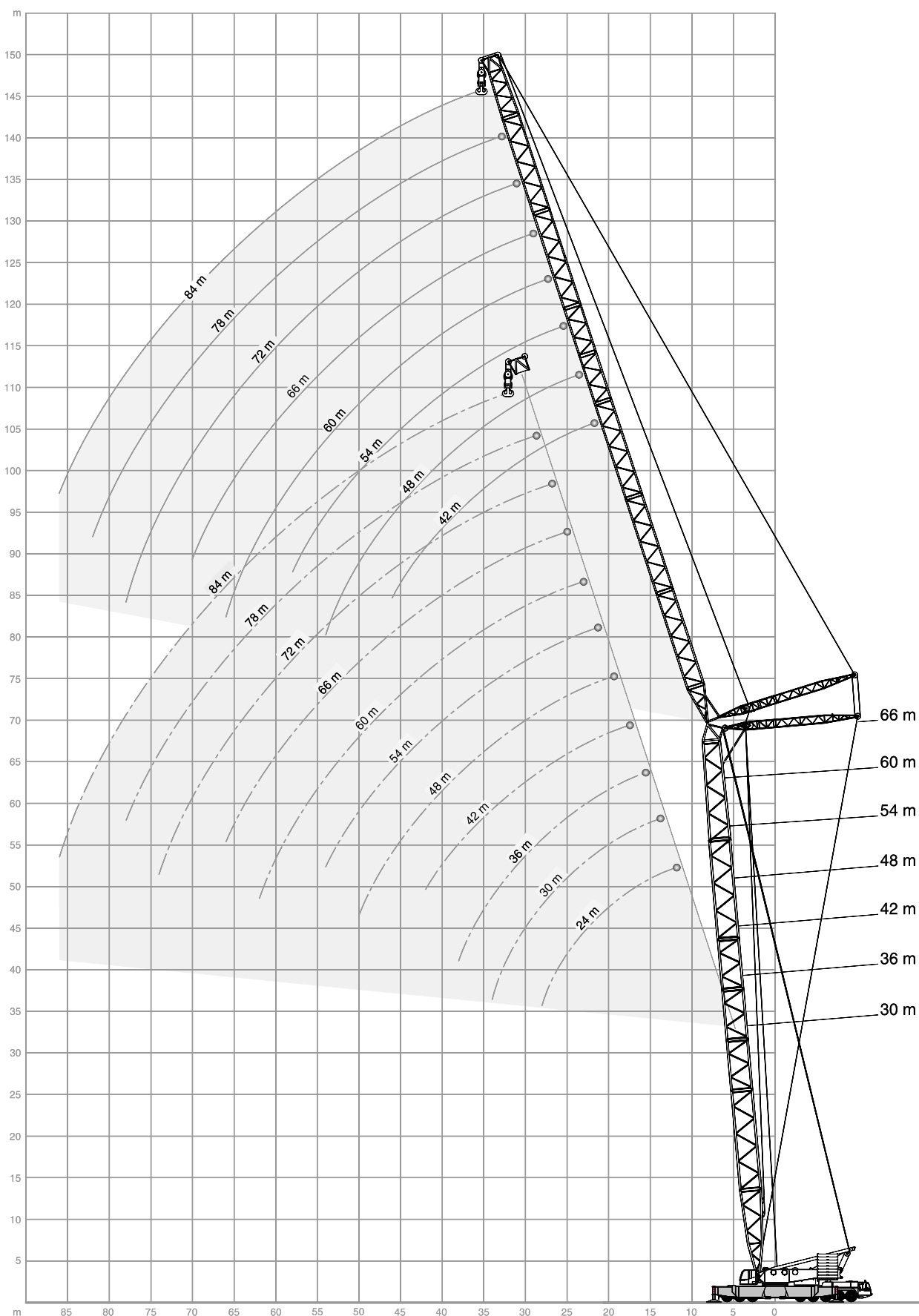

TEREX DEMAG TC 2800-1

AUTOJEŘÁB

//Tomáš Novotný
AUTOJEŘÁBY DEMOLICE s.r.o.

SW LIFTING CAPACITIES · TRAGFÄHIGKEITEN ·
CAPACITÉS DE LEVAGE

200 t 14 m x 14 m 360° DIN/ISO

30 m

m	24 m			30 m			36 m			42 m			48 m			54 m		
	85°	75°	65°	85°	75°	65°	85°	75°	65°	85°	75°	65°	85°	75°	65°	85°	75°	65°
14	t	t	t	t	t	t	t	t	t	t	t	t	t	t	t	t	t	t
16	287,0	-	-	-	-	-	-	-	-	-	-	-	-	-	-	-	-	-
18	252,0	-	-	245,0	-	-	-	-	-	-	-	-	-	-	-	-	-	-
20	221,0	-	-	220,0	-	-	206,0	-	-	-	-	-	-	-	-	-	-	-
22	196,0	-	-	195,0	-	-	194,0	-	-	182,0	-	-	-	-	-	-	-	-
24	175,0	-	-	174,0	-	-	173,0	-	-	172,0	-	-	156,0	-	-	-	-	-
26	155,0	147,0	-	154,0	-	-	154,0	-	-	152,0	-	-	151,0	-	-	136,0	-	-
28	137,0	131,0	-	137,0	130,0	-	136,0	-	-	135,0	-	-	135,0	-	-	133,0	-	-
30	123,0	118,0	-	123,0	117,0	-	122,0	-	-	121,0	-	-	121,0	-	-	120,0	-	-
32	-	107,0	-	111,0	106,0	-	111,0	105,0	-	110,0	-	-	109,0	-	-	108,0	-	-
34	-	97,5	93,0	102,2	96,5	-	102,0	95,5	-	101,0	94,5	-	100,2	-	-	99,2	-	-
36	-	-	85,5	93,5	88,5	-	93,0	88,0	-	92,0	87,0	-	91,5	86,0	-	90,5	-	-
38	-	-	79,0	-	82,0	77,5	86,2	81,0	-	85,2	80,0	-	84,7	79,0	-	83,7	-	-
40	-	-	73,0	-	76,0	72,0	79,5	75,0	-	78,5	74,0	-	78,0	73,5	-	77,0	72,0	-
42	-	-	-	-	-	67,0	-	70,0	66,0	73,5	69,0	-	73,0	68,0	-	72,0	67,0	-
44	-	-	-	-	-	62,5	-	65,5	61,5	68,5	64,5	-	68,0	63,5	-	67,0	62,5	-
46	-	-	-	-	-	-	-	61,5	58,0	-	60,5	56,5	63,7	59,5	-	62,7	58,5	-
48	-	-	-	-	-	-	-	-	54,5	-	56,5	53,0	59,5	56,0	52,5	58,5	55,0	-
50	-	-	-	-	-	-	-	-	48,6	-	50,5	47,5	53,0	49,9	46,6	52,0	48,7	45,3
54	-	-	-	-	-	-	-	-	-	-	-	42,6	-	44,7	41,7	46,8	43,5	40,4
56	-	-	-	-	-	-	-	-	-	-	-	-	-	42,5	39,5	-	41,3	38,3
58	-	-	-	-	-	-	-	-	-	-	-	-	-	-	37,6	-	39,2	36,3
62	-	-	-	-	-	-	-	-	-	-	-	-	-	-	-	-	35,6	32,9
66	-	-	-	-	-	-	-	-	-	-	-	-	-	-	-	-	-	29,9

m	60 m			66 m			72 m			78 m			84 m		
	85°	75°	65°	85°	75°	65°	85°	75°	65°	85°	75°	65°	85°	75°	65°
26	t	t	t	t	t	t	t	t	t	t	t	t	t	t	t
28	117,0	-	-	-	-	-	-	-	-	-	-	-	-	-	-
30	117,0	-	-	102,0	-	-	-	-	-	-	-	-	-	-	-
34	107,0	-	-	102,0	-	-	89,0	-	-	-	-	-	-	-	-
38	90,0	-	-	89,0	-	-	88,0	-	-	76,0	-	-	66,0	-	-
40	76,5	-	-	76,0	-	-	75,0	-	-	74,0	-	-	66,0	-	-
42	71,2	66,5	-	70,7	-	-	69,7	-	-	69,2	-	-	64,5	-	-
44	66,0	61,5	-	65,5	-	-	64,5	-	-	64,5	-	-	63,0	-	-
46	62,0	57,5	-	61,5	57,0	-	60,5	-	-	60,2	-	-	59,0	-	-
48	58,0	54,0	-	57,5	53,5	-	56,5	52,0	-	56,0	-	-	55,0	-	-
50	51,5	48,0	-	51,0	47,2	-	49,9	46,0	-	49,6	45,7	-	48,8	-	-
52	48,8	45,2	-	48,2	44,5	-	47,1	43,3	-	46,8	43,0	-	46,0	42,0	-
54	46,1	42,8	39,6	45,5	42,1	-	44,4	40,9	-	44,1	40,5	-	43,3	39,6	-
58	41,5	38,4	35,5	40,9	37,7	34,7	39,8	36,5	-	39,5	36,2	-	38,6	35,2	-
62	37,7	34,7	32,0	37,0	34,0	31,2	35,9	32,8	29,9	35,6	32,5	-	34,7	31,5	-
66	-	31,6	29,0	33,6	30,8	28,2	32,5	29,6	26,7	32,2	29,3	26,2	31,3	28,3	-
68	-	30,2	27,6	-	29,4	26,8	31,0	28,2	25,3	30,7	27,8	24,8	29,8	26,8	-
70	-	-	26,4	-	28,1	25,5	29,6	26,9	24,0	29,2	26,5	23,5	28,3	25,4	22,3
74	-	-	-	-	25,8	23,1	27,1	24,5	21,6	26,7	24,0	21,1	25,8	22,8	19,9
78	-	-	-	-	-	21,1	-	22,3	19,5	24,4	21,7	19,0	23,5	20,6	17,8
80	-	-	-	-	-	-	-	21,3	18,6	-	20,7	18,0	22,4	19,5	16,8
82	-	-	-	-	-	-	-	-	17,7	-	19,7	17,1	21,4	18,6	15,9
84	-	-	-	-	-	-	-	-	-	-	18,9	16,3	20,4	17,7	15,0
86	-	-	-	-	-	-	-	-	-	-	-	15,5	19,5	16,8	14,2
90	-	-	-	-	-	-	-	-	-	-	-	14,0	-	15,3	12,8
94	-	-	-	-	-	-	-	-	-	-	-	-	-	-	11,5

Remarks · Bemerkungen · Remarques

Main boom angle 85°, 75° and 65°, capacities for intermediate boom positions are calculated by the crane control system IC-1
 Hauptauslegerwinkel 85°, 75° und 65°, Traglasten für Zwischenstellungen des Hauptauslegers werden von der Kransteuerung IC-1 berechnet
 Jarret de flèche principale 85°, 75° et 65°, le système de commande de la grue IC-1 calcule les charges pour les positions intermédiaires de la flèche

TEREX DEMAG TC 2800-1

AUTOJEŘÁB

//Tomáš Novotný
AUTOJEŘÁBY DEMOLICE s.r.o.

SW LIFTING CAPACITIES · TRAGFÄHIGKEITEN ·
CAPACITÉS DE LEVAGE

200 t 14 m x 14 m 360° DIN/ISO

36 m

m	24 m			30 m			36 m			42 m			48 m			54 m		
	85°	75°	65°	85°	75°	65°	85°	75°	65°	85°	75°	65°	85°	75°	65°	85°	75°	65°
16	t	t	t	t	t	t	t	t	t	t	t	t	t	t	t	t	t	t
18	250,0	-	-	-	-	-	-	-	-	-	-	-	-	-	-	-	-	-
20	220,0	-	-	218,0	-	-	189,0	-	-	-	-	-	-	-	-	-	-	-
22	194,0	-	-	193,0	-	-	189,0	-	-	164,0	-	-	-	-	-	-	-	-
24	173,0	-	-	172,0	-	-	172,0	-	-	164,0	-	-	139,0	-	-	-	-	-
26	154,0	-	-	154,0	-	-	153,0	-	-	151,0	-	-	139,0	-	-	120,0	-	-
28	137,0	129,0	-	136,0	-	-	136,0	-	-	135,0	-	-	134,0	-	-	120,0	-	-
30	123,0	116,0	-	122,0	115,0	-	122,0	-	-	121,0	-	-	120,0	-	-	119,0	-	-
34	-	105,0	-	111,0	104,0	-	110,0	103,0	-	109,0	-	-	109,0	-	-	108,0	-	-
36	-	88,0	82,5	93,0	87,0	-	92,5	86,5	-	91,5	85,0	-	91,0	-	-	90,0	-	-
38	-	-	76,5	-	80,5	-	86,0	79,5	-	85,0	78,5	-	84,5	77,5	-	83,2	-	-
40	-	-	71,0	-	74,5	69,5	79,5	74,0	-	78,5	72,5	-	78,0	72,0	-	76,5	-	-
42	-	-	-	-	69,5	65,0	-	68,5	-	73,2	67,5	-	72,7	67,0	-	71,5	65,5	-
44	-	-	-	-	-	60,5	-	64,0	59,5	68,0	63,0	-	67,5	62,5	-	66,5	61,0	-
46	-	-	-	-	-	53,5	-	56,5	52,5	60,0	55,5	51,0	59,5	54,5	-	58,5	53,5	-
48	-	-	-	-	-	-	-	-	46,7	-	49,6	45,6	53,0	48,7	44,6	52,0	47,6	-
50	-	-	-	-	-	-	-	-	-	-	46,9	43,1	-	46,1	42,1	49,3	44,9	-
52	-	-	-	-	-	-	-	-	-	-	-	40,8	-	43,7	39,9	46,6	42,5	38,6
54	-	-	-	-	-	-	-	-	-	-	-	-	-	39,4	35,9	42,1	38,2	34,6
56	-	-	-	-	-	-	-	-	-	-	-	-	-	-	32,5	-	34,6	31,2
58	-	-	-	-	-	-	-	-	-	-	-	-	-	-	-	-	33,1	29,7
60	-	-	-	-	-	-	-	-	-	-	-	-	-	-	-	-	-	28,4
62	-	-	-	-	-	-	-	-	-	-	-	-	-	-	-	-	-	25,8
64	-	-	-	-	-	-	-	-	-	-	-	-	-	-	-	-	-	25,8
66	-	-	-	-	-	-	-	-	-	-	-	-	-	-	-	-	-	25,8
68	-	-	-	-	-	-	-	-	-	-	-	-	-	-	-	-	-	25,8
70	-	-	-	-	-	-	-	-	-	-	-	-	-	-	-	-	-	25,8
72	-	-	-	-	-	-	-	-	-	-	-	-	-	-	-	-	-	25,8
74	-	-	-	-	-	-	-	-	-	-	-	-	-	-	-	-	-	25,8

m	60 m			66 m			72 m			78 m			84 m		
	85°	75°	65°	85°	75°	65°	85°	75°	65°	85°	75°	65°	85°	75°	65°
26	t	t	t	t	t	t	t	t	t	t	t	t	t	t	t
28	107,0	-	-	-	-	-	-	-	-	-	-	-	-	-	-
30	107,0	-	-	93,0	-	-	-	-	-	-	-	-	-	-	-
34	89,5	-	-	88,0	-	-	80,0	-	-	70,0	-	-	61,0	-	-
38	76,0	-	-	75,5	-	-	74,0	-	-	70,0	-	-	61,0	-	-
42	66,0	60,5	-	65,5	-	-	64,0	-	-	64,0	-	-	60,0	-	-
44	61,7	56,5	-	61,2	55,5	-	60,0	-	-	60,0	-	-	57,5	-	-
46	57,5	52,5	-	57,0	52,0	-	56,0	-	-	56,0	-	-	55,0	-	-
48	54,2	49,7	-	53,7	49,0	-	52,8	47,7	-	52,7	-	-	51,7	-	-
50	51,0	46,8	-	50,5	46,0	-	49,6	44,8	-	49,4	44,5	-	48,5	-	-
54	45,9	41,7	-	45,2	40,9	-	44,1	39,7	-	43,9	39,4	-	43,0	38,4	-
58	41,3	37,4	33,7	40,6	36,7	-	39,5	35,5	-	39,3	35,1	-	38,4	34,1	-
62	37,4	33,8	30,3	36,7	33,0	29,4	35,6	31,8	-	35,3	31,5	-	34,5	30,5	-
66	-	30,7	27,3	33,4	29,9	26,3	32,3	28,7	24,8	32,0	28,3	-	31,1	27,2	-
70	-	28,0	24,7	-	27,2	23,7	29,4	25,9	22,2	29,0	25,5	21,7	28,1	24,3	-
74	-	-	22,4	-	24,9	21,4	26,9	23,4	19,9	26,5	23,0	19,4	25,5	21,8	18,1
78	-	-	-	-	-	19,4	-	21,3	17,9	24,2	20,7	17,3	23,3	19,6	16,1
80	-	-	-	-	-	-	-	20,3	17,0	-	19,7	16,4	22,2	18,6	15,2
82	-	-	-	-	-	-	-	-	16,1	-	18,8	15,5	21,1	17,6	14,3
86	-	-	-	-	-	-	-	-	14,6	-	17,1	14,0	19,3	15,9	12,7
90	-	-	-	-	-	-	-	-	-	-	-	12,6	-	14,4	11,3
92	-	-	-	-	-	-	-	-	-	-	-	-	-	13,7	10,6
94	-	-	-	-	-	-	-	-	-	-	-	-	-	-	10,0
98	-	-	-	-	-	-	-	-	-	-	-	-	-	-	8,9
102	-	-	-	-	-	-	-	-	-	-	-	-	-	-	-

Remarks · Bemerkungen · Remarques

Main boom angle 85°, 75° and 65°, capacities for intermediate boom positions are calculated by the crane control system IC-1
 Hauptauslegerwinkel 85°, 75° und 65°, Traglasten für Zwischenstellungen des Hauptauslegers werden von der Kransteuerung IC-1 berechnet
 Jarret de flèche principale 85°, 75° et 65°, le système de commande de la grue IC-1 calcule les charges pour les positions intermédiaires de la flèche

TEREX DEMAG TC 2800-1

AUTOJEŘÁB

//Tomáš Novotný
AUTOJEŘÁBY DEMOLICE s.r.o.

SW LIFTING CAPACITIES · TRAGFÄHIGKEITEN ·
CAPACITÉS DE LEVAGE

200 t 14 m x 14 m 360° DIN/ISO

42 m

m	24 m			30 m			36 m			42 m			48 m			54 m		
	85°	75°	65°	85°	75°	65°	85°	75°	65°	85°	75°	65°	85°	75°	65°	85°	75°	65°
	t	t	t	t	t	t	t	t	t	t	t	t	t	t	t	t	t	t
16	241,0	-	-	-	-	-	-	-	-	-	-	-	-	-	-	-	-	-
18	218,0	-	-	207,0	-	-	-	-	-	-	-	-	-	-	-	-	-	-
20	192,0	-	-	191,0	-	-	167,0	-	-	-	-	-	-	-	-	-	-	-
22	172,0	-	-	171,0	-	-	166,0	-	-	145,0	-	-	-	-	-	-	-	-
24	154,0	-	-	153,0	-	-	151,0	-	-	144,0	-	-	128,0	-	-	-	-	-
26	137,0	127,0	-	136,0	-	-	135,0	-	-	134,0	-	-	128,0	-	-	-	110,0	-
28	123,0	114,0	-	122,0	-	-	122,0	-	-	120,0	-	-	119,0	-	-	-	110,0	-
30	-	103,0	-	111,0	102,0	-	110,0	-	-	109,0	-	-	108,0	-	-	-	107,0	-
32	-	94,0	-	102,0	93,0	-	101,2	92,0	-	100,2	-	-	99,2	-	-	-	98,2	-
34	-	86,5	-	93,0	85,5	-	92,5	84,5	-	91,5	-	-	90,5	-	-	-	89,5	-
36	-	80,0	-	-	79,0	-	85,7	78,0	-	84,7	76,5	-	84,0	-	-	-	83,0	-
38	-	-	68,0	-	73,0	-	79,0	72,0	-	78,0	71,0	-	77,5	70,0	-	-	76,5	-
40	-	-	63,5	-	68,0	-	-	67,0	-	73,0	66,0	-	72,2	65,0	-	-	71,2	64,0
42	-	-	59,5	-	63,5	58,0	-	63,0	-	68,0	61,5	-	67,0	61,0	-	-	66,0	59,5
46	-	-	-	-	-	51,0	-	55,5	50,0	60,0	54,0	-	59,0	53,5	-	-	58,0	52,0
48	-	-	-	-	-	-	-	52,0	47,3	-	51,0	-	55,7	50,0	-	-	54,7	49,1
50	-	-	-	-	-	-	-	-	44,6	-	48,3	43,4	52,5	47,5	-	-	51,5	46,3
54	-	-	-	-	-	-	-	-	40,0	-	43,4	38,8	-	42,5	37,9	-	46,3	41,3
58	-	-	-	-	-	-	-	-	-	-	-	35,0	-	38,3	34,0	-	41,8	37,1
60	-	-	-	-	-	-	-	-	-	-	-	-	-	36,5	32,3	-	-	35,3
62	-	-	-	-	-	-	-	-	-	-	-	-	-	-	30,8	-	-	33,6
64	-	-	-	-	-	-	-	-	-	-	-	-	-	-	29,3	-	-	32,0
66	-	-	-	-	-	-	-	-	-	-	-	-	-	-	28,0	-	-	-
70	-	-	-	-	-	-	-	-	-	-	-	-	-	-	-	-	-	26,4
74	-	-	-	-	-	-	-	-	-	-	-	-	-	-	-	-	-	23,9

m	60 m			66 m			72 m			78 m			84 m		
	85°	75°	65°	85°	75°	65°	85°	75°	65°	85°	75°	65°	85°	75°	65°
26	96,0	-	-	-	-	-	-	-	-	-	-	-	-	-	-
28	96,0	-	-	86,0	-	-	-	-	-	-	-	-	-	-	-
30	96,0	-	-	86,0	-	-	73,0	-	-	-	-	-	-	-	-
34	88,0	-	-	86,0	-	-	73,0	-	-	66,0	-	-	57,0	-	-
38	76,0	-	-	75,0	-	-	72,0	-	-	66,0	-	-	57,0	-	-
42	65,5	-	-	65,0	-	-	64,0	-	-	63,0	-	-	56,0	-	-
44	61,5	55,0	-	61,0	-	-	59,7	-	-	59,2	-	-	55,0	-	-
46	57,5	51,5	-	57,0	50,5	-	55,5	-	-	55,5	-	-	54,0	-	-
50	51,0	45,5	-	50,0	44,7	-	49,3	43,4	-	49,1	-	-	48,2	-	-
52	48,3	42,9	-	47,4	42,1	-	46,5	40,8	-	46,3	40,5	-	45,4	-	-
54	45,6	40,5	-	44,9	39,7	-	43,8	38,5	-	43,6	38,1	-	42,7	37,1	-
58	41,0	36,3	-	40,4	35,5	-	39,2	34,3	-	39,0	33,9	-	38,1	32,9	-
62	37,2	32,7	28,2	36,5	32,0	27,2	35,3	30,7	-	35,1	30,4	-	34,2	29,2	-
66	-	29,7	25,3	33,1	28,9	24,3	32,0	27,5	22,7	31,7	27,1	-	30,8	26,0	-
70	-	27,1	22,8	30,3	26,2	21,8	29,1	24,7	20,2	28,8	24,3	19,7	27,9	23,1	-
74	-	-	20,6	-	23,8	19,6	26,6	22,3	18,0	26,2	21,9	17,5	25,3	20,7	16,2
76	-	-	19,6	-	22,7	18,6	-	21,2	17,0	25,1	20,7	16,5	24,1	19,6	15,2
78	-	-	18,7	-	-	17,7	-	20,2	16,1	24,0	19,7	15,6	23,0	18,5	14,3
82	-	-	-	-	-	16,0	-	18,3	14,4	-	17,8	13,8	20,8	16,6	12,6
86	-	-	-	-	-	-	-	-	12,9	-	16,1	12,3	19,0	14,9	11,1
88	-	-	-	-	-	-	-	-	12,3	-	15,4	11,6	-	14,1	10,4
90	-	-	-	-	-	-	-	-	11,7	-	-	11,0	-	13,4	9,7
94	-	-	-	-	-	-	-	-	-	-	-	9,8	-	12,1	8,5
98	-	-	-	-	-	-	-	-	-	-	-	-	-	-	7,4
102	-	-	-	-	-	-	-	-	-	-	-	-	-	-	-

Remarks · Bemerkungen · Remarques

Main boom angle 85°, 75° and 65°, capacities for intermediate boom positions are calculated by the crane control system IC-1
 Hauptauslegerwinkel 85°, 75° und 65°, Traglasten für Zwischenstellungen des Hauptauslegers werden von der Kransteuerung IC-1 berechnet
 Jarret de flèche principale 85°, 75° et 65°, le système de commande de la grue IC-1 calcule les charges pour les positions intermédiaires de la flèche

TEREX DEMAG TC 2800-1

AUTOJEŘÁB

//Tomáš Novotný
AUTOJEŘÁBY DEMOLICE s.r.o.

SW LIFTING CAPACITIES · TRAGFÄHIGKEITEN ·
CAPACITÉS DE LEVAGE

200 t		14 m x 14 m									360°			DIN/ISO					
48 m		24 m			30 m			36 m			42 m			48 m			54 m		
		85°	75°	65°	85°	75°	65°	85°	75°	65°	85°	75°	65°	85°	75°	65°	85°	75°	65°
m	t	t	t	t	t	t	t	t	t	t	t	t	t	t	t	t	t	t	t
16	212,0	-	-	-	-	-	-	-	-	-	-	-	-	-	-	-	-	-	-
18	212,0	-	-	-	181,0	-	-	-	-	-	-	-	-	-	-	-	-	-	-
20	191,0	-	-	-	181,0	-	-	156,0	-	-	-	-	-	-	-	-	-	-	-
22	170,0	-	-	-	166,0	-	-	156,0	-	-	136,0	-	-	-	-	-	-	-	-
24	153,0	-	-	-	152,0	-	-	146,0	-	-	136,0	-	-	117,0	-	-	-	-	-
26	136,0	-	-	-	135,0	-	-	134,0	-	-	130,0	-	-	117,0	-	-	103,0	-	-
28	122,0	111,0	-	-	122,0	-	-	121,0	-	-	119,0	-	-	116,0	-	-	103,0	-	-
30	111,0	101,0	-	-	110,0	-	-	110,0	-	-	108,0	-	-	107,0	-	-	102,0	-	-
32	-	92,0	-	-	101,2	91,0	-	101,0	-	-	99,5	-	-	98,5	-	-	95,5	-	-
34	-	84,5	-	-	92,5	83,5	-	92,0	82,5	-	91,0	-	-	90,0	-	-	89,0	-	-
36	-	78,0	-	-	-	77,0	-	85,2	76,0	-	84,2	75,0	-	83,5	-	-	82,5	-	-
38	-	72,5	-	-	-	71,5	-	78,5	70,5	-	77,5	69,5	-	77,0	-	-	76,0	-	-
40	-	-	-	-	-	66,5	-	-	65,5	-	72,5	64,5	-	72,0	63,5	-	71,0	-	-
42	-	-	57,0	-	-	62,0	-	-	61,0	-	67,5	60,0	-	67,0	59,0	-	66,0	58,0	-
44	-	-	53,0	-	-	58,5	52,0	-	57,5	-	63,5	56,0	-	63,0	55,5	-	61,7	54,0	-
46	-	-	50,0	-	-	-	49,0	-	54,0	-	59,5	52,5	-	59,0	52,0	-	57,5	50,5	-
48	-	-	-	-	-	-	46,2	-	50,5	44,9	-	49,8	-	55,5	48,9	-	54,2	47,7	-
50	-	-	-	-	-	-	43,6	-	48,1	42,3	-	47,0	41,1	52,0	46,1	-	51,0	44,9	-
54	-	-	-	-	-	-	-	-	-	37,9	-	42,1	36,7	-	41,2	35,7	45,9	40,0	-
58	-	-	-	-	-	-	-	-	-	-	-	-	33,0	-	37,1	31,9	41,4	35,9	30,3
60	-	-	-	-	-	-	-	-	-	-	-	-	31,4	-	35,3	30,2	-	34,1	28,6
62	-	-	-	-	-	-	-	-	-	-	-	-	29,8	-	-	28,6	-	32,4	27,1
66	-	-	-	-	-	-	-	-	-	-	-	-	-	-	25,9	-	29,5	24,3	-
70	-	-	-	-	-	-	-	-	-	-	-	-	-	-	-	-	-	-	21,9
74	-	-	-	-	-	-	-	-	-	-	-	-	-	-	-	-	-	-	19,8

60 m		66 m			72 m			78 m			84 m		
		85°	75°	65°	85°	75°	65°	85°	75°	65°	85°	75°	65°
m	t	t	t	t	t	t	t	t	t	t	t	t	t
28	91,0	-	-	-	-	-	-	-	-	-	-	-	-
30	91,0	-	-	-	79,0	-	-	-	-	-	-	-	-
34	88,0	-	-	-	79,0	-	-	70,0	-	-	61,0	-	-
38	75,5	-	-	-	74,0	-	-	69,0	-	-	61,0	-	-
42	65,0	-	-	-	64,5	-	-	63,0	-	-	60,0	-	-
46	57,0	50,0	-	-	56,5	-	-	55,5	-	-	55,0	-	-
48	53,7	46,9	-	-	53,2	46,1	-	52,2	-	-	51,8	-	-
50	50,5	44,1	-	-	50,0	43,3	-	48,9	42,0	-	48,7	-	-
54	45,3	39,2	-	-	44,6	38,4	-	43,5	37,1	-	43,3	36,8	-
56	43,0	37,1	-	-	42,3	36,3	-	41,2	35,0	-	41,0	34,6	-
58	40,7	35,1	-	-	40,0	34,3	-	38,9	33,0	-	38,7	32,7	-
62	36,9	31,6	26,0	-	36,2	30,8	-	35,0	29,4	-	34,8	29,0	-
66	-	28,6	23,2	-	32,8	27,7	22,1	31,7	26,2	-	31,4	25,8	-
70	-	25,9	20,8	-	30,0	25,0	19,7	28,8	23,5	18,1	28,5	23,1	-
72	-	24,7	19,7	-	-	23,8	18,7	27,5	22,3	17,0	27,2	21,8	-
74	-	-	18,7	-	-	22,6	17,6	26,3	21,1	16,0	25,9	20,7	15,5
78	-	-	16,9	-	-	20,6	15,8	-	19,0	14,2	23,7	18,6	13,7
82	-	-	-	-	-	-	14,2	-	17,2	12,6	21,7	16,7	12,0
84	-	-	-	-	-	-	13,5	-	16,4	11,8	-	15,9	11,3
86	-	-	-	-	-	-	12,8	-	-	11,2	-	15,1	10,6
90	-	-	-	-	-	-	-	-	-	9,9	-	13,6	9,3
94	-	-	-	-	-	-	-	-	-	-	-	8,2	-
96	-	-	-	-	-	-	-	-	-	-	-	7,7	-
98	-	-	-	-	-	-	-	-	-	-	-	7,2	-
102	-	-	-	-	-	-	-	-	-	-	-	-	5,0

Remarks · Bemerkungen · Remarques

Main boom angle 85°, 75° and 65°, capacities for intermediate boom positions are calculated by the crane control system IC-1
 Hauptauslegerwinkel 85°, 75° und 65°, Traglasten für Zwischenstellungen des Hauptauslegers werden von der Kransteuerung IC-1 berechnet
 Jarret de flèche principale 85°, 75° et 65°, le système de commande de la grue IC-1 calcule les charges pour les positions intermédiaires de la flèche

TEREX DEMAG TC 2800-1

AUTOJEŘÁB

//Tomáš Novotný
AUTOJEŘÁBY DEMOLICE s.r.o.

SW LIFTING CAPACITIES · TRAGFÄHIGKEITEN ·
CAPACITÉS DE LEVAGE

200 t		14 m x 14 m									360°			DIN/ISO					
54 m		24 m			30 m			36 m			42 m			48 m			54 m		
		85°	75°	65°	85°	75°	65°	85°	75°	65°	85°	75°	65°	85°	75°	65°	85°	75°	65°
m	t	t	t	t	t	t	t	t	t	t	t	t	t	t	t	t	t	t	t
16	183,0	-	-	-	-	-	-	-	-	-	-	-	-	-	-	-	-	-	-
18	183,0	-	-	-	164,0	-	-	-	-	-	-	-	-	-	-	-	-	-	-
20	171,0	-	-	-	164,0	-	-	142,0	-	-	-	-	-	-	-	-	-	-	-
22	161,0	-	-	-	161,0	-	-	142,0	-	-	123,0	-	-	-	-	-	-	-	-
24	150,0	-	-	-	146,0	-	-	139,0	-	-	123,0	-	-	107,0	-	-	-	-	-
26	136,0	-	-	-	134,0	-	-	130,0	-	-	122,0	-	-	107,0	-	-	95,0	-	-
28	122,0	-	-	-	121,0	-	-	120,0	-	-	117,0	-	-	107,0	-	-	95,0	-	-
30	110,0	98,5	-	-	110,0	-	-	109,0	-	-	107,0	-	-	103,0	-	-	95,0	-	-
32	-	90,0	-	-	101,0	89,0	-	100,2	-	-	98,7	-	-	96,2	-	-	91,5	-	-
34	-	82,5	-	-	92,0	81,5	-	91,5	-	-	90,5	-	-	89,5	-	-	88,0	-	-
36	-	76,5	-	-	-	75,0	-	84,7	74,0	-	83,7	-	-	83,0	-	-	81,7	-	-
38	-	70,5	-	-	-	69,5	-	78,0	68,5	-	77,0	67,5	-	76,5	-	-	75,5	-	-
40	-	66,0	-	-	-	65,0	-	73,0	64,0	-	72,0	62,5	-	71,5	-	-	70,5	-	-
42	-	-	54,0	-	-	60,5	-	68,0	59,5	-	67,0	58,5	-	66,5	57,5	-	65,5	-	-
44	-	-	50,5	-	-	56,5	-	-	55,5	-	63,0	54,5	-	62,5	53,5	-	61,5	52,5	-
46	-	-	47,8	-	-	-	46,5	-	52,5	-	59,0	51,0	-	58,5	50,5	-	57,5	49,2	-
50	-	-	-	-	-	-	41,3	-	46,7	40,0	-	45,6	-	52,0	44,7	-	50,5	43,4	-
54	-	-	-	-	-	-	37,0	-	-	35,7	-	40,8	34,4	-	39,9	-	45,6	38,6	-
56	-	-	-	-	-	-	-	-	-	33,8	-	38,7	32,4	-	37,8	-	43,3	36,6	-
58	-	-	-	-	-	-	-	-	-	32,1	-	-	30,7	-	35,9	29,5	41,1	34,6	-
62	-	-	-	-	-	-	-	-	-	-	-	-	27,6	-	32,5	26,4	-	31,2	24,7
66	-	-	-	-	-	-	-	-	-	-	-	-	25,0	-	-	23,7	-	28,3	22,1
68	-	-	-	-	-	-	-	-	-	-	-	-	-	-	-	22,5	-	27,0	20,9
70	-	-	-	-	-	-	-	-	-	-	-	-	-	-	-	21,5	-	-	19,8
74	-	-	-	-	-	-	-	-	-	-	-	-	-	-	-	-	-	-	17,8

		60 m			66 m			72 m			78 m			84 m		
		85°	75°	65°	85°	75°	65°	85°	75°	65°	85°	75°	65°	85°	75°	65°
m	t	t	t	t	t	t	t	t	t	t	t	t	t	t	t	t
28	82,0	-	-	-	-	-	-	-	-	-	-	-	-	-	-	-
30	82,0	-	-	-	73,0	-	-	-	-	-	-	-	-	-	-	-
34	81,0	-	-	-	73,0	-	-	64,0	-	-	-	-	-	-	-	-
38	74,0	-	-	-	71,0	-	-	63,0	-	-	56,0	-	-	48,0	-	-
42	64,5	-	-	-	64,0	-	-	62,0	-	-	55,0	-	-	48,0	-	-
46	56,5	48,4	-	-	56,0	-	-	55,0	-	-	54,0	-	-	47,0	-	-
50	50,0	42,6	-	-	49,7	41,8	-	48,5	-	-	48,0	-	-	46,0	-	-
52	47,4	40,1	-	-	46,9	39,3	-	45,8	38,0	-	45,4	-	-	44,0	-	-
54	44,9	37,8	-	-	44,2	37,0	-	43,1	35,7	-	42,9	-	-	42,0	-	-
56	42,6	35,8	-	-	41,9	34,9	-	40,8	33,5	-	40,6	33,1	-	39,7	-	-
58	40,4	33,8	-	-	39,7	33,0	-	38,6	31,5	-	38,3	31,1	-	37,4	29,9	-
62	36,5	30,4	-	-	35,8	29,5	-	34,7	27,9	-	34,4	27,5	-	33,5	26,3	-
66	-	27,3	21,0	-	32,5	26,4	-	31,4	24,9	-	31,1	24,5	-	30,2	23,2	-
70	-	24,7	18,7	-	29,7	23,7	17,6	28,5	22,2	-	28,2	21,8	-	27,3	20,6	-
74	-	22,4	16,7	-	-	21,4	15,6	26,0	19,9	14,0	25,6	19,5	-	24,7	18,2	-
78	-	-	15,0	-	-	19,4	13,9	-	17,9	12,3	23,4	17,4	11,7	22,3	16,2	-
80	-	-	14,2	-	-	18,5	13,1	-	16,9	11,5	22,3	16,5	10,9	21,2	15,2	-
82	-	-	13,5	-	-	-	12,4	-	16,1	10,7	21,3	15,6	10,2	20,2	14,4	8,9
86	-	-	-	-	-	-	11,0	-	14,6	9,4	-	14,0	8,8	18,3	12,7	7,5
90	-	-	-	-	-	-	-	-	-	8,2	-	12,6	7,6	-	11,3	6,3
92	-	-	-	-	-	-	-	-	-	7,7	-	12,0	7,1	-	10,7	5,7
94	-	-	-	-	-	-	-	-	-	7,2	-	-	6,5	-	10,0	5,2
96	-	-	-	-	-	-	-	-	-	-	-	-	6,0	-	9,5	4,7
98	-	-	-	-	-	-	-	-	-	-	-	-	5,6	-	-	4,2
102	-	-	-	-	-	-	-	-	-	-	-	-	-	-	-	-

Remarks · Bemerkungen · Remarques

Main boom angle 85°, 75° and 65°, capacities for intermediate boom positions are calculated by the crane control system IC-1
 Hauptauslegerwinkel 85°, 75° und 65°, Traglasten für Zwischenstellungen des Hauptauslegers werden von der Kransteuerung IC-1 berechnet
 Jarret de flèche principale 85°, 75° et 65°, le système de commande de la grue IC-1 calcule les charges pour les positions intermédiaires de la flèche

TEREX DEMAG TC 2800-1

AUTOJEŘÁB

//Tomáš Novotný
AUTOJEŘÁBY DEMOLICE s.r.o.

SW LIFTING CAPACITIES · TRAGFÄHIGKEITEN ·
CAPACITÉS DE LEVAGE

200 t 14 m x 14 m 360° DIN/ISO

60 m

m	24 m			30 m			36 m			42 m			48 m			54 m		
	85°	75°	65°	85°	75°	65°	85°	75°	65°	85°	75°	65°	85°	75°	65°	85°	75°	65°
	t	t	t	t	t	t	t	t	t	t	t	t	t	t	t	t	t	t
18	168,0	-	-	-	-	-	-	-	-	-	-	-	-	-	-	-	-	-
20	158,0	-	-	144,0	-	-	132,0	-	-	-	-	-	-	-	-	-	-	-
22	149,0	-	-	137,0	-	-	132,0	-	-	110,0	-	-	-	-	-	-	-	-
24	140,0	-	-	130,0	-	-	132,0	-	-	110,0	-	-	96,0	-	-	-	-	-
26	131,0	-	-	124,0	-	-	123,0	-	-	110,0	-	-	96,0	-	-	86,0	-	-
28	121,0	-	-	117,0	-	-	116,0	-	-	108,0	-	-	96,0	-	-	86,0	-	-
30	110,0	-	-	109,0	-	-	108,0	-	-	105,0	-	-	95,0	-	-	86,0	-	-
32	-	87,5	-	100,2	-	-	99,5	-	-	97,2	-	-	91,5	-	-	84,5	-	-
34	-	80,5	-	91,5	79,0	-	91,0	-	-	89,5	-	-	88,0	-	-	83,0	-	-
38	-	69,0	-	-	67,5	-	78,0	66,5	-	76,5	-	-	76,0	-	-	74,0	-	-
40	-	64,0	-	-	63,0	-	72,7	62,0	-	71,5	60,5	-	71,0	-	-	69,5	-	-
42	-	-	-	-	59,0	-	67,5	57,5	-	66,5	56,5	-	66,0	55,5	-	65,0	-	-
46	-	-	45,1	-	51,5	-	-	50,5	-	58,5	49,7	-	58,0	48,8	-	57,0	47,5	-
50	-	-	40,1	-	-	38,7	-	45,2	-	-	44,0	-	51,5	43,1	-	50,5	41,8	-
52	-	-	-	-	-	36,5	-	42,7	-	-	41,6	-	48,9	40,7	-	47,8	39,4	-
54	-	-	-	-	-	34,5	-	-	32,9	-	39,3	-	46,3	38,5	-	45,2	37,2	-
58	-	-	-	-	-	-	-	-	29,4	-	35,4	28,0	-	34,5	-	40,7	33,2	-
62	-	-	-	-	-	-	-	-	26,5	-	-	25,0	-	31,2	23,9	-	29,8	-
64	-	-	-	-	-	-	-	-	-	-	-	23,7	-	29,8	22,5	-	28,3	-
66	-	-	-	-	-	-	-	-	-	-	-	22,5	-	-	21,3	-	26,9	19,7
70	-	-	-	-	-	-	-	-	-	-	-	-	-	19,2	-	24,3	17,5	-
74	-	-	-	-	-	-	-	-	-	-	-	-	-	17,3	-	-	15,6	-
78	-	-	-	-	-	-	-	-	-	-	-	-	-	-	-	-	14,0	-

m	60 m			66 m			72 m			78 m			84 m		
	85°	75°	65°	85°	75°	65°	85°	75°	65°	85°	75°	65°	85°	75°	65°
	t	t	t	t	t	t	t	t	t	t	t	t	t	t	t
28	75,0	-	-	-	-	-	-	-	-	-	-	-	-	-	-
30	75,0	-	-	66,0	-	-	-	-	-	-	-	-	-	-	-
34	74,0	-	-	66,0	-	-	58,0	-	-	50,0	-	-	-	-	-
38	71,0	-	-	64,0	-	-	58,0	-	-	50,0	-	-	44,0	-	-
42	64,0	-	-	62,0	-	-	56,0	-	-	49,0	-	-	44,0	-	-
46	56,0	-	-	55,0	-	-	54,0	-	-	48,0	-	-	43,0	-	-
48	52,9	43,7	-	52,1	-	-	51,0	-	-	47,0	-	-	42,5	-	-
50	49,9	41,0	-	49,2	-	-	48,0	-	-	46,0	-	-	42,0	-	-
52	47,2	38,6	-	46,5	37,7	-	45,3	-	-	44,0	-	-	41,5	-	-
54	44,5	36,4	-	43,9	35,5	-	42,7	33,9	-	42,0	-	-	41,0	-	-
56	42,2	34,3	-	41,6	33,3	-	40,4	31,7	-	40,0	31,3	-	39,0	-	-
58	40,0	32,4	-	39,3	31,4	-	38,2	29,8	-	38,0	29,4	-	37,0	-	-
60	38,1	30,5	-	37,4	29,6	-	36,2	28,0	-	36,0	27,6	-	35,1	26,3	-
62	36,2	28,9	-	35,5	27,9	-	34,3	26,3	-	34,1	25,9	-	33,2	24,7	-
66	-	25,9	18,6	32,2	24,9	-	31,0	23,4	-	30,8	23,0	-	29,8	21,7	-
70	-	23,3	16,4	29,3	22,3	15,3	28,1	20,8	-	27,9	20,4	-	26,9	19,1	-
74	-	21,1	14,5	-	20,1	13,4	25,7	18,5	11,7	25,3	18,1	-	24,3	16,9	-
76	-	20,1	13,7	-	19,1	12,6	-	17,5	10,9	24,1	17,1	-	23,1	15,8	-
78	-	-	12,9	-	18,1	11,8	-	16,6	10,1	23,0	16,1	9,6	21,9	14,9	-
82	-	-	11,5	-	16,5	10,4	-	14,8	8,7	21,0	14,4	8,2	19,8	13,1	6,8
86	-	-	10,3	-	-	9,1	-	13,3	7,4	-	12,8	6,9	18,0	11,5	5,5
90	-	-	-	-	-	8,0	-	-	6,3	-	11,4	5,7	-	10,2	4,4
92	-	-	-	-	-	-	-	-	5,8	-	10,8	5,2	-	9,5	-
94	-	-	-	-	-	-	-	-	5,3	-	-	4,7	-	8,9	-
96	-	-	-	-	-	-	-	-	-	-	-	4,3	-	8,4	-
98	-	-	-	-	-	-	-	-	-	-	-	-	-	7,9	-
102	-	-	-	-	-	-	-	-	-	-	-	-	-	-	-

Remarks · Bemerkungen · Remarques

Main boom angle 85°, 75° and 65°, capacities for intermediate boom positions are calculated by the crane control system IC-1
 Hauptauslegerwinkel 85°, 75° und 65°, Traglasten für Zwischenstellungen des Hauptauslegers werden von der Kransteuerung IC-1 berechnet
 Jarret de flèche principale 85°, 75° et 65°, le système de commande de la grue IC-1 calcule les charges pour les positions intermédiaires de la flèche

TEREX DEMAG TC 2800-1

AUTOJEŘÁB

//Tomáš Novotný
AUTOJEŘÁBY DEMOLICE s.r.o.

SW LIFTING CAPACITIES · TRAGFÄHIGKEITEN ·
CAPACITÉS DE LEVAGE

200 t 14 m x 14 m 360° DIN/ISO

66 m

m	24 m			30 m			36 m			42 m			48 m			54 m		
	85°	75°	65°	85°	75°	65°	85°	75°	65°	85°	75°	65°	85°	75°	65°	85°	75°	65°
	t	t	t	t	t	t	t	t	t	t	t	t	t	t	t	t	t	t
18	136,0	-	-	-	-	-	-	-	-	-	-	-	-	-	-	-	-	-
20	136,0	-	-	121,0	-	-	-	-	-	-	-	-	-	-	-	-	-	-
22	128,0	-	-	121,0	-	-	105,0	-	-	-	-	-	-	-	-	-	-	-
24	122,0	-	-	113,0	-	-	105,0	-	-	96,0	-	-	-	-	-	-	-	-
26	115,0	-	-	107,0	-	-	99,0	-	-	96,0	-	-	85,0	-	-	-	-	-
28	109,0	-	-	102,0	-	-	95,0	-	-	95,0	-	-	85,0	-	-	74,0	-	-
30	103,0	-	-	97,5	-	-	91,0	-	-	92,0	-	-	84,0	-	-	74,0	-	-
32	-	85,0	-	93,0	-	-	87,2	-	-	89,0	-	-	81,0	-	-	73,0	-	-
34	-	78,0	-	88,5	-	-	83,5	-	-	86,0	-	-	78,0	-	-	72,0	-	-
36	-	72,0	-	-	71,0	-	80,0	-	-	80,5	-	-	76,0	-	-	70,5	-	-
38	-	67,0	-	-	65,5	-	76,5	64,5	-	75,0	-	-	74,0	-	-	69,0	-	-
42	-	58,0	-	-	57,0	-	67,0	56,0	-	66,0	54,5	-	65,0	-	-	64,0	-	-
44	-	-	-	-	53,5	-	-	52,0	-	62,0	51,0	-	61,2	50,0	-	60,0	-	-
46	-	-	-	-	50,0	-	-	49,1	-	58,0	48,0	-	57,5	47,1	-	56,0	-	-
48	-	-	-	-	47,3	-	-	46,2	-	-	45,1	-	54,2	44,2	-	53,0	42,8	-
50	-	-	37,3	-	-	35,7	-	43,6	-	-	42,4	-	51,0	41,5	-	50,0	40,2	-
54	-	-	33,2	-	-	31,7	-	39,0	30,1	-	37,9	-	45,9	37,0	-	44,7	35,6	-
58	-	-	-	-	-	28,4	-	-	26,8	-	34,1	25,3	-	33,2	-	40,3	31,6	-
60	-	-	-	-	-	-	-	-	25,3	-	32,4	23,9	-	31,4	-	-	29,9	-
62	-	-	-	-	-	-	-	-	24,0	-	-	22,6	-	29,8	21,4	-	28,3	-
66	-	-	-	-	-	-	-	-	-	-	-	20,2	-	27,0	19,0	-	25,4	17,3
70	-	-	-	-	-	-	-	-	-	-	-	18,2	-	-	16,9	-	22,9	15,3
72	-	-	-	-	-	-	-	-	-	-	-	-	-	-	16,0	-	21,9	14,3
74	-	-	-	-	-	-	-	-	-	-	-	-	-	-	15,2	-	-	13,5
78	-	-	-	-	-	-	-	-	-	-	-	-	-	-	-	-	-	12,0
82	-	-	-	-	-	-	-	-	-	-	-	-	-	-	-	-	-	10,7
86	-	-	-	-	-	-	-	-	-	-	-	-	-	-	-	-	-	-

m	60 m			66 m			72 m			78 m			84 m		
	85°	75°	65°	85°	75°	65°	85°	75°	65°	85°	75°	65°	85°	75°	65°
28	t	t	t	t	t	t	t	t	t	t	t	t	t	t	t
30	66,0	-	-	58,0	-	-	-	-	-	-	-	-	-	-	-
34	66,0	-	-	58,0	-	-	51,0	-	-	44,0	-	-	-	-	-
38	63,0	-	-	57,0	-	-	51,0	-	-	44,0	-	-	39,0	-	-
42	60,0	-	-	55,0	-	-	49,0	-	-	44,0	-	-	39,0	-	-
46	55,0	-	-	52,0	-	-	47,0	-	-	43,0	-	-	38,0	-	-
50	49,0	39,4	-	48,0	-	-	45,0	-	-	42,0	-	-	37,0	-	-
52	46,5	36,9	-	45,5	35,9	-	43,5	-	-	41,0	-	-	36,5	-	-
54	44,1	34,7	-	43,0	33,6	-	42,0	-	-	40,0	-	-	36,0	-	-
56	41,8	32,6	-	40,9	31,6	-	39,5	30,0	-	38,5	-	-	35,0	-	-
58	39,6	30,7	-	38,9	29,7	-	37,0	28,1	-	37,0	27,7	-	34,0	-	-
62	35,8	27,3	-	35,1	26,3	-	33,9	24,7	-	33,0	24,3	-	32,0	23,0	-
66	32,5	24,4	-	31,8	23,4	-	30,6	21,8	-	30,4	21,4	-	29,0	20,2	-
70	-	21,9	14,1	29,0	20,9	-	27,8	19,3	-	27,5	18,9	-	26,4	17,7	-
74	-	19,7	12,4	-	18,7	11,2	25,3	17,2	-	25,0	16,8	-	23,9	15,5	-
76	-	18,8	11,6	-	17,7	10,5	24,2	16,2	-	23,8	15,8	-	22,7	14,5	-
78	-	-	10,8	-	16,8	9,7	23,1	15,3	8,0	22,6	14,8	-	21,5	13,6	-
82	-	-	9,5	-	15,2	8,4	-	13,6	6,7	20,6	13,1	6,1	19,4	11,9	-
86	-	-	8,3	-	-	7,2	-	12,1	5,5	-	11,6	4,9	17,6	10,3	-
88	-	-	-	-	-	6,6	-	11,5	4,9	-	10,9	4,4	-	9,7	-
90	-	-	-	-	-	6,2	-	-	4,4	-	10,3	-	-	9,0	-
94	-	-	-	-	-	5,3	-	-	-	-	9,1	-	-	7,8	-
98	-	-	-	-	-	-	-	-	-	-	-	-	-	6,8	-
100	-	-	-	-	-	-	-	-	-	-	-	-	-	6,3	-
102	-	-	-	-	-	-	-	-	-	-	-	-	-	-	-

Remarks · Bemerkungen · Remarques

see page 42 · siehe Seite 42 · voir page 42

TEREX DEMAG TC 2800-1

AUTOJEŘÁB

//Tomáš Novotný
AUTOJEŘÁBY DEMOLICE s.r.o.

SWSL WORKING RANGES · ARBEITSBEREICHE ·
PORTÉES

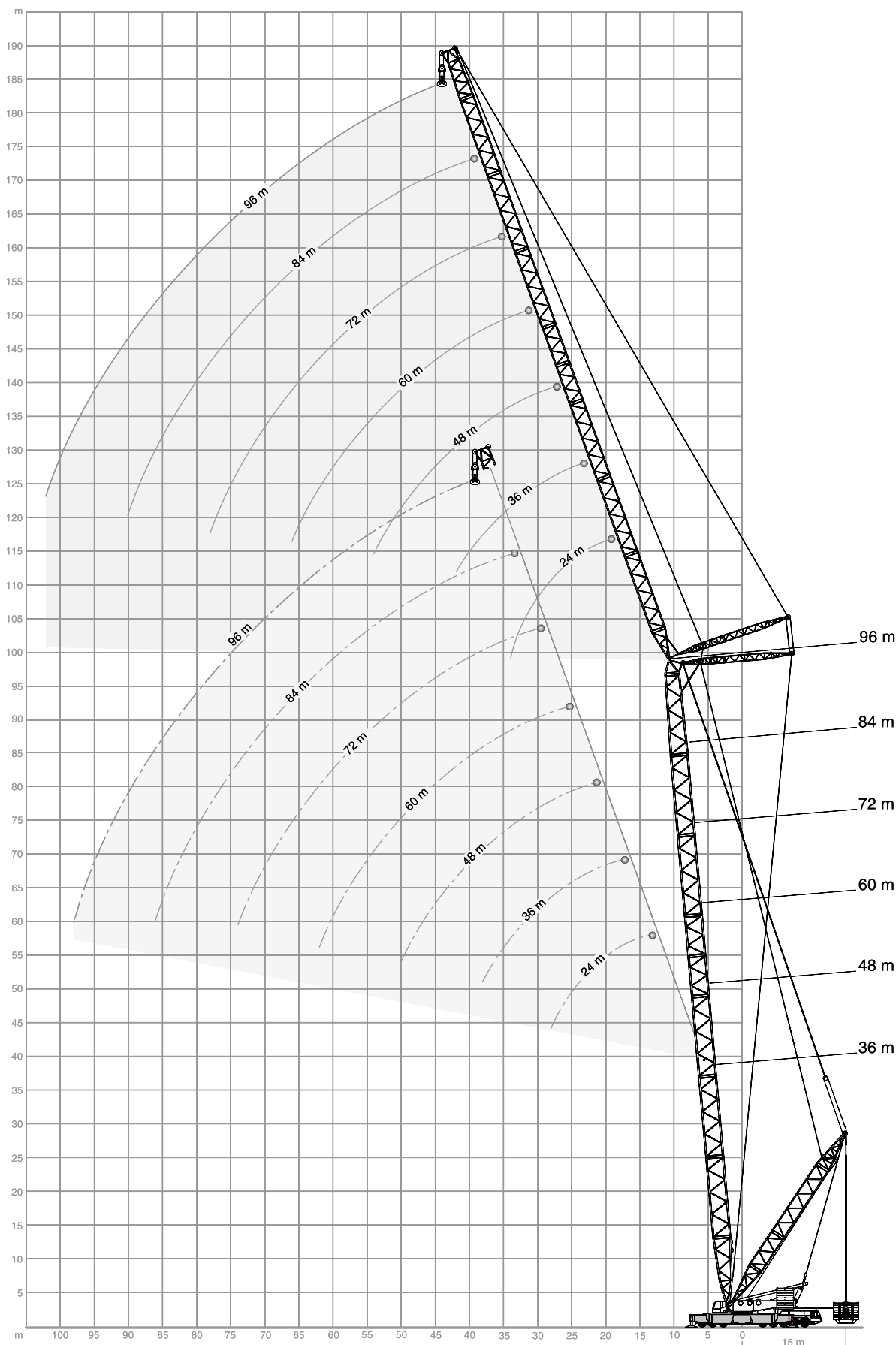

TEREX DEMAG TC 2800-1

AUTOJEŘÁB

//Tomáš Novotný
AUTOJEŘÁBY DEMOLICE s.r.o.

SWSL / SFSL 15° / HSWSL

LIFTING CAPACITIES · TRAGFÄHIGKEITEN · CAPACITÉS DE LEVAGE

14 m x 14 m 11-15 m 360° DIN/ISO

36 m + 24 m

m	SWSL		SFSL	HSWSL			
	0 t	0 t-250 t					
	200 t	160 t					
	85°	85°	75°	65°	55°	85°	
t	t	t	t	t	t	t	
16	208,0	300,0	-	-	-	300,0	-
18	180,0	300,0	-	-	-	300,0	-
20	159,0	300,0	-	-	-	300,0	-
22	142,0	273,0	-	-	-	283,0	-
24	127,0	247,0	-	-	-	263,0	-
26	116,0	214,0	218,0	-	-	246,0	-
28	106,0	182,0	204,0	-	-	231,0	-
30	-	-	191,0	-	-	217,0	-
34	-	-	170,0	167,0	-	189,0	-
38	-	-	-	155,0	-	161,0	-
40	-	-	-	147,0	-	151,5	-
42	-	-	-	-	129,0	142,0	-
46	-	-	-	-	121,0	123,0	-
50	-	-	-	-	-	107,0	-
54	-	-	-	-	-	90,5	-

36 m + 36 m

m	t	t	t	t	t	t	t
18	179,0	257,0	-	-	-	-	-
20	157,0	257,0	-	-	-	253,0	-
22	140,0	253,0	-	-	-	249,0	-
24	126,0	239,0	-	-	-	245,0	-
26	114,0	222,0	-	-	-	239,0	-
28	104,0	204,0	-	-	-	224,0	-
30	95,5	187,0	173,0	-	-	208,0	-
34	82,0	152,0	163,0	-	-	185,0	-
38	71,0	123,0	147,0	-	-	167,0	-
42	-	-	134,0	134,0	-	148,0	-
46	-	-	118,0	124,0	-	129,0	-
50	-	-	-	113,0	-	115,0	-
52	-	-	-	108,0	103,0	108,0	-
54	-	-	-	-	99,0	101,0	-
58	-	-	-	-	92,5	90,0	-
62	-	-	-	-	-	78,0	-
66	-	-	-	-	-	66,0	-

36 m + 48 m

m	t	t	t	t	t	t	t
22	138,0	187,0	-	-	-	-	-
24	124,0	187,0	-	-	-	186,0	-
26	112,0	187,0	-	-	-	185,0	-
28	102,0	180,0	-	-	-	183,0	-
30	93,5	172,0	-	-	-	181,0	-
34	80,0	156,0	-	-	-	164,0	-
36	74,5	146,0	139,0	-	-	156,5	-
38	69,0	136,0	139,0	-	-	149,0	-
42	60,5	116,0	129,0	-	-	138,0	-
46	53,5	99,5	118,0	-	-	126,0	-
50	47,9	84,0	109,0	107,0	-	115,0	-
54	-	-	97,5	99,5	-	103,0	-
58	-	-	82,0	93,0	-	94,0	-
60	-	-	-	89,5	82,0	89,2	-
62	-	-	-	86,5	81,0	84,5	-
64	-	-	-	83,0	78,5	79,2	-
66	-	-	-	-	76,0	75,0	-
68	-	-	-	-	73,5	71,0	-
70	-	-	-	-	-	67,0	-
74	-	-	-	-	-	58,5	-
78	-	-	-	-	-	49,8	-

36 m + 60 m

m	SWSL		SFSL	HSWSL		
	0 t	0 t-250 t				
	200 t	160 t				
	85°	85°	75°	65°	55°	85°
t	t	t	t	t	t	t
26	110,0	134,0	-	-	-	-
28	100,0	134,0	-	-	-	134,0
30	91,5	134,0	-	-	-	133,0
34	77,5	128,0	-	-	-	133,0
38	67,0	119,0	-	-	-	130,0
42	58,5	110,0	117,0	-	-	124,0
46	51,5	100,0	112,0	-	-	116,0
50	45,6	90,0	102,0	-	-	105,0
54	40,7	78,5	96,0	-	-	94,0
56	38,6	73,5	93,0	83,5	-	90,2
58	36,6	68,5	88,5	83,5	-	86,5
62	32,9	58,5	78,0	77,5	-	81,5
66	-	-	68,0	72,0	-	76,5
70	-	-	58,0	67,5	65,0	70,5
74	-	-	-	63,0	62,0	62,5
76	-	-	-	60,5	60,5	59,5
78	-	-	-	-	59,0	57,0
80	-	-	-	-	57,5	53,5
82	-	-	-	-	-	50,0
86	-	-	-	-	-	43,7
90	-	-	-	-	-	37,0

36 m + 72 m

m	t	t	t	t	t	t	t
30	89,0	96,0	-	-	-	-	-
34	75,0	96,0	-	-	-	95,0	-
38	64,5	94,0	-	-	-	94,0	-
42	56,0	91,0	-	-	-	93,0	-
46	49,1	87,0	-	-	-	91,0	-
48	46,2	85,0	87,0	-	-	89,5	-
50	43,3	83,0	86,0	-	-	88,0	-
54	38,4	79,0	84,0	-	-	83,0	-
58	34,2	72,0	81,0	-	-	78,0	-
62	30,6	64,0	78,0	-	-	73,0	-
64	29,0	60,2	75,5	67,0	-	70,5	-
66	27,5	56,5	71,5	66,5	-	68,0	-
70	24,7	49,8	64,0	63,5	-	64,0	-
74	22,3	42,8	57,0	60,5	-	61,0	-
78	-	-	50,0	57,0	54,5	57,5	-
80	-	-	46,8	55,5	54,5	55,5	-
82	-	-	-	54,0	53,5	53,5	-
86	-	-	-	49,8	50,0	48,3	-
90	-	-	-	-	47,1	42,7	-
92	-	-	-	-	45,6	40,0	-
94	-	-	-	-	-	37,3	-
98	-	-	-	-	-	32,1	-
102	-	-	-	-	-	26,9	-

Remarks · Bemerkungen · Remarques

Main boom angle 85°, 75°, 65° and 55°; capacities for intermediate boom positions are calculated by the crane control system IC-1

Hauptauslegerwinkel 85°, 75°, 65° und 55°; Traglasten für Zwischenstellungen des Hauptauslegers werden von der Kransteuerung IC-1 berechnet

Jarret de flèche principale 85°, 75°, 65° et 55°; le système de commande de la grue IC-1 calcule les charges pour les positions intermédiaires de la flèche

For HSWSL a boom power-kit is required · Für HSWSL ist ein Ausleger-Verstärkungs-Kit erforderlich · Un kit à fortifier de flèche principale est nécessaire pour HSWSL

SWSL / SFSL 15° / HSWSL

LIFTING CAPACITIES · TRAGFÄHIGKEITEN · CAPACITÉS DE LEVAGE

14 m x 14 m

11-15 m

360°

DIN/ISO

36 m + 84 m

m	0 t		0 t-250 t				SFSL	HSWSL
	200 t		160 t					
	85°	85°	75°	65°	55°	85°		
34	64,0	69,0	-	-	-	-	-	
38	63,0	69,0	-	-	-	69,0	-	
42	54,5	68,0	-	-	-	68,0	-	
46	47,7	68,0	-	-	-	68,0	-	
50	41,9	67,0	-	-	-	67,0	-	
54	37,0	66,0	63,0	-	-	66,0	-	
58	32,7	65,0	63,0	-	-	64,0	-	
62	29,1	63,0	62,0	-	-	62,0	-	
66	25,9	59,0	61,0	-	-	60,0	-	
70	23,2	53,0	57,0	-	-	57,0	-	
72	21,9	50,2	56,0	50,0	-	56,0	-	
74	20,7	47,4	56,0	50,0	-	55,0	-	
78	18,5	42,2	53,0	49,8	-	52,0	-	
82	16,6	37,2	47,8	48,3	-	50,0	-	
86	14,9	31,9	42,8	46,7	-	46,0	-	
88	-	-	40,3	45,7	42,9	44,5	-	
90	-	-	37,9	44,7	42,7	43,0	-	
92	-	-	35,3	43,6	42,3	41,0	-	
94	-	-	-	42,5	41,7	39,0	-	
98	-	-	-	37,9	39,5	36,0	-	
102	-	-	-	-	37,1	32,0	-	
104	-	-	-	-	35,9	29,9	-	
106	-	-	-	-	-	27,9	-	
110	-	-	-	-	-	23,7	-	
114	-	-	-	-	-	19,3	-	

48 m + 24 m

m	t	t	t	t	t	t	t
16	206,0	296,0	-	-	-	298,0	-
18	178,0	296,0	-	-	-	298,0	-
20	157,0	292,0	-	-	-	297,0	-
22	140,0	277,0	-	-	-	296,0	-
24	126,0	262,0	-	-	-	282,0	-
26	114,0	229,0	-	-	-	262,0	-
28	104,0	196,0	208,0	-	-	241,0	-
30	96,0	162,0	205,0	-	-	227,0	-
34	-	-	178,0	-	-	195,0	-
38	-	-	157,0	-	-	170,0	-
40	-	-	-	143,0	-	160,0	-
42	-	-	-	135,0	-	150,0	-
46	-	-	-	122,0	-	133,0	-
50	-	-	-	-	-	120,0	-
54	-	-	-	-	-	104,0	-
58	-	-	-	-	-	90,5	-
62	-	-	-	-	-	80,5	-
66	-	-	-	-	-	68,5	-
70	-	-	-	-	-	-	-

48 m + 36 m

m	0 t		0 t-250 t				SFSL	HSWSL
	200 t		160 t					
	85°	85°	75°	65°	55°	85°		
20	155,0	222,0	-	-	-	-	-	
22	138,0	218,0	-	-	-	221,0	-	
24	124,0	211,0	-	-	-	219,0	-	
26	112,0	203,0	-	-	-	218,0	-	
28	102,0	194,0	-	-	-	216,0	-	
30	94,0	184,0	-	-	-	206,0	-	
34	80,5	159,0	164,0	-	-	188,0	-	
38	70,0	129,0	152,0	-	-	171,0	-	
42	-	-	139,0	-	-	151,0	-	
46	-	-	125,0	-	-	134,0	-	
48	-	-	119,0	114,0	-	127,5	-	
50	-	-	109,0	109,0	-	121,0	-	
54	-	-	-	99,5	-	108,0	-	
56	-	-	-	95,5	-	103,5	-	
58	-	-	-	-	88,0	99,0	-	
62	-	-	-	-	81,5	87,5	-	
64	-	-	-	-	78,5	82,0	-	
66	-	-	-	-	-	76,5	-	
70	-	-	-	-	-	69,5	-	
74	-	-	-	-	-	60,0	-	
78	-	-	-	-	-	51,0	-	

48 m + 48 m

m	t	t	t	t	t	t	t
24	122,0	162,0	-	-	-	-	-
26	110,0	162,0	-	-	-	162,0	-
28	100,0	160,0	-	-	-	162,0	-
30	92,0	157,0	-	-	-	162,0	-
34	78,5	149,0	-	-	-	160,0	-
38	68,0	136,0	-	-	-	149,0	-
40	63,7	128,0	136,0	-	-	143,0	-
42	59,5	120,0	133,0	-	-	137,0	-
46	52,5	102,0	123,0	-	-	128,0	-
50	46,9	86,5	112,0	-	-	118,0	-
54	-	-	102,0	97,5	-	108,0	-
58	-	-	93,0	90,0	-	98,5	-
60	-	-	85,0	86,5	-	93,7	-
62	-	-	-	83,0	-	89,0	-
66	-	-	-	77,0	-	82,0	-
68	-	-	-	74,5	71,0	77,7	-
70	-	-	-	-	69,0	73,5	-
74	-	-	-	-	64,5	65,5	-
76	-	-	-	-	62,0	62,0	-
78	-	-	-	-	-	59,5	-
82	-	-	-	-	-	52,5	-
86	-	-	-	-	-	45,9	-
90	-	-	-	-	-	38,9	-

Remarks · Bemerkungen · Remarques

Main boom angle 85°, 75°, 65° and 55°; capacities for intermediate boom positions are calculated by the crane control system IC-1
 Hauptauslegerwinkel 85°, 75°, 65° und 55°; Traglasten für Zwischenstellungen des Hauptauslegers werden von der Kransteuerung IC-1 berechnet
 Jarret de flèche principale 85°, 75°, 65° et 55°; le système de commande de la grue IC-1 calcule les charges pour les positions intermédiaires de la flèche

For HSWSL a boom power-kit is required
 Für HSWSL ist ein Ausleger-Verstärkungs-Kit erforderlich
 Un kit à fortifier de flèche principale est nécessaire pour HSWSL

TEREX DEMAG TC 2800-1

AUTOJEŘÁB

//Tomáš Novotný
AUTOJEŘÁBY DEMOLICE s.r.o.

SWSL / SFSL 15° / HSWSL

LIFTING CAPACITIES · TRAGFÄHIG-
KEITEN · CAPACITÉS DE LEVAGE

14 m x 14 m 11-15 m 360° DIN/ISO

48 m + 60 m

m	SWSL						SFSL	HSWSL
	0 t		0 t-250 t				120,0	-
	200 t	160 t						
85°	85°	75°	65°	55°	85°			
28	98,5	120,0	-	-	-	-	-	
30	90,0	120,0	-	-	-	120,0	-	
34	76,0	117,0	-	-	-	120,0	-	
38	65,5	112,0	-	-	-	120,0	-	
42	57,0	106,0	-	-	-	117,0	-	
46	50,0	98,0	110,0	-	-	114,0	-	
50	44,6	91,0	105,0	-	-	107,0	-	
54	39,8	80,5	95,0	-	-	98,0	-	
58	35,6	70,0	87,0	-	-	90,0	-	
62	32,1	60,0	80,0	78,0	-	83,0	-	
66	-	-	74,0	74,5	-	76,0	-	
70	-	-	65,0	69,5	-	71,0	-	
72	-	-	60,0	67,0	-	68,7	-	
74	-	-	-	65,0	-	66,5	-	
76	-	-	-	63,0	57,5	64,2	-	
78	-	-	-	61,0	57,5	62,0	-	
80	-	-	-	59,0	55,5	58,7	-	
82	-	-	-	-	54,5	55,5	-	
86	-	-	-	-	51,0	49,9	-	
88	-	-	-	-	49,9	47,6	-	
90	-	-	-	-	-	45,3	-	
94	-	-	-	-	-	39,7	-	
98	-	-	-	-	-	34,2	-	
102	-	-	-	-	-	28,6	-	
106	-	-	-	-	-	-	-	

48 m + 84 m

m	SWSL						SFSL	HSWSL
	0 t		0 t-250 t				64,0	-
	200 t	160 t						
85°	85°	75°	65°	55°	85°			
34	59,0	64,0	-	-	-	-	-	
38	58,5	64,0	-	-	-	64,0	-	
42	53,5	63,0	-	-	-	63,0	-	
46	46,6	62,0	-	-	-	63,0	-	
50	40,8	61,0	-	-	-	63,0	-	
54	35,9	60,0	-	-	-	62,0	-	
56	33,8	60,0	58,0	-	-	61,5	-	
58	31,8	60,0	58,0	-	-	61,0	-	
62	28,2	59,0	58,0	-	-	59,0	-	
66	25,1	58,0	58,0	-	-	57,0	-	
70	22,3	53,5	58,0	-	-	55,0	-	
74	19,9	48,0	58,0	-	-	53,0	-	
76	18,8	45,3	58,0	46,1	-	51,5	-	
78	17,7	42,7	56,5	46,1	-	50,0	-	
82	15,8	37,6	51,0	46,1	-	48,0	-	
86	14,1	32,4	45,9	45,7	-	44,4	-	
90	-	-	40,9	44,8	-	42,7	-	
94	-	-	35,9	43,7	38,8	40,5	-	
96	-	-	33,3	42,7	38,7	39,2	-	
98	-	-	-	41,8	38,6	38,0	-	
102	-	-	-	38,5	37,3	35,1	-	
104	-	-	-	36,0	36,3	33,8	-	
106	-	-	-	-	35,3	32,5	-	
110	-	-	-	-	33,5	28,6	-	
114	-	-	-	-	-	24,9	-	
118	-	-	-	-	-	21,2	-	
122	-	-	-	-	-	17,6	-	

48 m + 72 m

m	t	t	t	t	t	t	t
34	74,0	87,0	-	-	-	87,0	-
38	63,0	86,0	-	-	-	86,0	-
42	54,5	83,0	-	-	-	86,0	-
46	48,0	80,0	-	-	-	85,0	-
50	42,3	77,0	79,0	-	-	83,0	-
54	37,4	74,0	79,0	-	-	81,0	-
58	33,3	71,0	78,0	-	-	77,0	-
62	29,7	65,0	77,0	-	-	73,0	-
66	26,6	57,5	72,0	-	-	68,0	-
70	23,9	50,5	67,0	61,5	-	63,5	-
74	21,5	43,6	61,5	60,5	-	61,0	-
78	-	-	54,5	58,5	-	59,0	-
82	-	-	47,8	55,0	-	56,0	-
84	-	-	44,2	53,5	-	53,7	-
86	-	-	-	51,5	49,1	51,5	-
90	-	-	-	48,9	46,2	47,0	-
92	-	-	-	47,4	44,8	44,9	-
94	-	-	-	-	43,6	42,8	-
98	-	-	-	-	41,2	38,1	-
100	-	-	-	-	40,1	35,8	-
102	-	-	-	-	-	33,5	-
106	-	-	-	-	-	29,1	-
110	-	-	-	-	-	24,7	-
114	-	-	-	-	-	20,1	-
118	-	-	-	-	-	-	-

60 m + 24 m

m	t	t	t	t	t	t	t
17	-	-	-	-	-	-	272,0
18	176,0	247,0	-	-	-	249,0	267,0
20	155,0	238,0	-	-	-	247,0	257,0
22	138,0	228,0	-	-	-	246,0	245,0
24	124,0	218,0	-	-	-	245,0	234,0
26	112,0	206,0	-	-	-	238,0	221,0
28	102,0	193,0	-	-	-	226,0	205,0
30	94,0	182,0	-	-	-	214,0	183,0
31	-	-	-	-	-	208,7	165,0
32	-	-	180,0	-	-	203,5	-
34	-	-	174,0	-	-	193,0	-
38	-	-	154,0	-	-	167,0	-
40	-	-	145,0	-	-	157,0	-
42	-	-	-	-	-	147,0	-
44	-	-	-	123,0	-	139,0	-
46	-	-	-	117,0	-	131,0	-
50	-	-	-	106,0	-	117,0	-
54	-	-	-	-	-	106,0	-
56	-	-	-	-	89,0	101,0	-
58	-	-	-	-	85,5	96,0	-
60	-	-	-	-	82,5	90,2	-
62	-	-	-	-	-	84,5	-
66	-	-	-	-	-	74,5	-
70	-	-	-	-	-	66,0	-
74	-	-	-	-	-	58,0	-
78	-	-	-	-	-	49,4	-
82	-	-	-	-	-	-	-

Remarks · Bemerkungen · Remarques

see page 46 · siehe Seite 46 · voir page 46

TEREX DEMAG TC 2800-1

AUTOJEŘÁB

//Tomáš Novotný
AUTOJEŘÁBY DEMOLICE s.r.o.

SWSL / SFSL 15° / HSWSL

LIFTING CAPACITIES · TRAGFÄHIG-
KEITEN · CAPACITÉS DE LEVAGE

14 m x 14 m

11-15 m

360°

DIN/ISO

60 m + 36 m

m	SWSL							SFSL	HSWSL
	0 t		0 t-250 t						
	200 t		160 t						
	85°	85°	75°	65°	55°		85°		
t	t	t	t	t	t	t	t	t	
20	152,0	180,0	-	-	-	-	196,0		
22	135,0	180,0	-	-	-	179,0	193,0		
24	122,0	176,0	-	-	-	178,0	188,0		
26	110,0	171,0	-	-	-	178,0	183,0		
28	100,0	165,0	-	-	-	178,0	177,0		
30	92,5	160,0	-	-	-	178,0	171,0		
34	79,0	149,0	-	-	-	170,0	159,0		
38	68,5	137,0	150,0	-	-	163,0	137,0		
42	60,0	109,0	135,0	-	-	149,0	109,0		
46	-	-	122,0	-	-	132,0	-		
50	-	-	111,0	-	-	118,0	-		
52	-	-	106,0	99,5	-	112,0	-		
54	-	-	-	95,5	-	106,0	-		
58	-	-	-	87,5	-	96,5	-		
62	-	-	-	81,0	-	88,0	-		
66	-	-	-	-	71,0	79,5	-		
70	-	-	-	-	66,0	71,0	-		
72	-	-	-	-	64,0	67,0	-		
74	-	-	-	-	-	63,0	-		
78	-	-	-	-	-	56,0	-		
82	-	-	-	-	-	50,0	-		
86	-	-	-	-	-	43,6	-		

60 m + 60 m

m	SWSL							SFSL	HSWSL
	0 t		0 t-250 t						
	200 t		160 t						
	85°	85°	75°	65°	55°		85°		
t	t	t	t	t	t	t	t	t	
28	96,5	102,0	-	-	-	-	109,0		
30	88,0	102,0	-	-	-	102,0	108,0		
34	74,5	101,0	-	-	-	102,0	104,0		
38	64,0	98,0	-	-	-	102,0	99,0		
42	55,5	95,0	-	-	-	101,0	93,0		
46	49,1	91,0	-	-	-	100,0	86,5		
48	46,2	88,5	96,0	-	-	100,0	83,0		
50	43,4	86,0	96,0	-	-	100,0	80,0		
54	38,6	82,0	94,0	-	-	93,0	75,0		
58	34,5	73,0	89,0	-	-	87,0	69,5		
62	31,0	63,0	83,0	-	-	81,0	63,0		
65	-	-	77,5	-	-	76,1	55,0		
66	-	-	76,0	70,5	-	74,5	-		
70	-	-	71,0	66,0	-	70,0	-		
74	-	-	63,0	61,5	-	66,0	-		
76	-	-	58,0	59,5	-	63,7	-		
78	-	-	-	57,5	-	61,5	-		
82	-	-	-	54,0	-	56,0	-		
84	-	-	-	52,5	48,9	53,2	-		
86	-	-	-	51,0	47,4	50,5	-		
90	-	-	-	-	44,6	45,2	-		
94	-	-	-	-	42,1	41,1	-		
98	-	-	-	-	-	36,8	-		
102	-	-	-	-	-	32,3	-		
106	-	-	-	-	-	28,0	-		
110	-	-	-	-	-	23,6	-		

60 m + 48 m

m	t	t	t	t	t	t	t
24	120,0	135,0	-	-	-	-	145,0
26	108,0	135,0	-	-	-	135,0	144,0
28	98,5	135,0	-	-	-	135,0	141,0
30	90,5	132,0	-	-	-	135,0	138,0
34	77,0	126,0	-	-	-	135,0	131,0
38	66,5	119,0	-	-	-	132,0	123,0
42	58,0	113,0	119,0	-	-	127,0	114,0
46	51,0	107,0	118,0	-	-	122,0	105,0
50	45,7	91,5	109,0	-	-	113,0	91,5
54	40,9	75,0	100,0	-	-	106,0	75,0
58	-	-	92,0	-	-	97,5	-
60	-	-	88,0	82,5	-	93,2	-
62	-	-	85,0	79,0	-	89,0	-
64	-	-	81,5	76,0	-	85,0	-
66	-	-	-	73,5	-	81,0	-
70	-	-	-	68,5	-	74,0	-
74	-	-	-	64,0	60,0	67,0	-
78	-	-	-	-	56,0	60,0	-
82	-	-	-	-	52,5	53,5	-
86	-	-	-	-	-	48,3	-
90	-	-	-	-	-	43,6	-
94	-	-	-	-	-	38,2	-
98	-	-	-	-	-	32,8	-

60 m + 72 m

m	t	t	t	t	t	t	t
32	-	-	-	-	-	-	79,0
34	72,0	77,0	-	-	-	77,0	78,5
38	61,5	76,0	-	-	-	77,0	76,0
42	53,0	74,0	-	-	-	77,0	73,5
46	46,6	72,0	-	-	-	76,0	70,5
50	41,0	70,0	-	-	-	75,0	68,0
54	36,2	68,0	71,0	-	-	74,0	65,0
58	32,1	66,0	71,0	-	-	72,0	62,0
62	28,6	63,0	71,0	-	-	69,0	59,0
66	25,5	59,5	69,0	-	-	65,0	56,0
70	22,9	52,5	64,0	-	-	62,0	52,5
74	20,5	45,9	60,0	55,5	-	58,0	45,9
77	-	-	57,0	55,0	-	56,1	40,4
78	-	-	56,0	55,0	-	55,5	-
82	-	-	52,0	52,0	-	54,0	-
86	-	-	46,6	48,8	-	50,5	-
90	-	-	-	45,9	-	46,3	-
92	-	-	-	44,6	41,0	43,9	-
94	-	-	-	43,3	39,8	41,6	-
96	-	-	-	42,1	38,6	39,4	-
98	-	-	-	-	37,5	37,8	-
102	-	-	-	-	35,4	34,1	-
106	-	-	-	-	33,6	30,3	-
110	-	-	-	-	-	26,6	-
114	-	-	-	-	-	23,0	-
118	-	-	-	-	-	19,4	-
122	-	-	-	-	-	15,8	-

Remarks · Bemerkungen · Remarques

Main boom angle 85°, 75°, 65° and 55°; capacities for intermediate boom positions are calculated by the crane control system IC-1

Hauptauslegerwinkel 85°, 75°, 65° und 55°; Traglasten für Zwischenstellungen des Hauptauslegers werden von der Kransteuerung IC-1 berechnet

Jarret de flèche principale 85°, 75°, 65° et 55°; le système de commande de la grue IC-1 calcule les charges pour les positions intermédiaires de la flèche

For HSWSL a boom power-kit is required · Für HSWSL ist ein Ausleger-Verstärkungs-Kit erforderlich · Un kit à fortifier de flèche principale est nécessaire pour HSWSL

TEREX DEMAG TC 2800-1

AUTOJEŘÁB

//Tomáš Novotný
AUTOJEŘÁBY DEMOLICE s.r.o.

SWSL / SFSL 15° / HSWSL

LIFTING CAPACITIES · TRAGFÄHIG-
KEITEN · CAPACITÉS DE LEVAGE

14 m x 14 m 11-15 m 360° DIN/ISO

60 m + 84 m

m	SWSL						SFSL	HSWSL
	0 t		0 t-250 t				t	t
	200 t	160 t						
	85°	85°	75°	65°	55°	85°		
35	-	-	-	-	-	-	58,0	
38	53,5	57,0	-	-	-	57,0	57,5	
42	52,0	57,0	-	-	-	57,0	56,5	
46	45,2	56,0	-	-	-	57,0	55,5	
50	39,5	55,0	-	-	-	57,0	54,5	
54	34,7	54,0	-	-	-	56,0	53,0	
58	30,6	53,0	-	-	-	55,0	52,0	
60	28,8	52,5	52,0	-	-	55,0	51,2	
62	27,1	52,0	52,0	-	-	55,0	50,5	
66	24,0	51,0	52,0	-	-	53,0	49,4	
70	21,3	49,0	52,0	-	-	51,0	47,4	
74	18,9	48,0	52,0	-	-	50,0	45,4	
78	16,8	44,0	52,0	-	-	48,0	43,4	
82	14,9	39,2	51,0	41,6	-	46,0	39,2	
86	13,2	34,2	48,0	41,6	-	44,0	34,2	
89	-	-	45,5	41,6	-	42,5	30,0	
90	-	-	45,0	41,6	-	42,0	-	
94	-	-	40,0	41,2	-	40,0	-	
98	-	-	35,1	39,4	-	38,0	-	
102	-	-	-	37,2	33,7	35,0	-	
106	-	-	-	35,2	31,8	31,9	-	
108	-	-	-	34,2	30,9	30,2	-	
110	-	-	-	-	30,1	28,5	-	
114	-	-	-	-	28,5	25,3	-	
118	-	-	-	-	27,0	22,1	-	
122	-	-	-	-	-	19,0	-	
126	-	-	-	-	-	16,0	-	
130	-	-	-	-	-	13,0	-	
134	-	-	-	-	-	9,8	-	

72 m + 36 m

m	SWSL						SFSL	HSWSL
	0 t		0 t-250 t				t	t
	200 t	160 t						
	85°	85°	75°	65°	55°	85°		
22	133,0	139,0	-	-	-	-	163,0	
24	119,0	136,0	-	-	-	138,0	159,0	
26	108,0	134,0	-	-	-	138,0	154,0	
28	98,5	130,0	-	-	-	138,0	150,0	
30	90,5	126,0	-	-	-	138,0	145,0	
34	77,0	119,0	-	-	-	136,0	136,0	
38	66,5	112,0	-	-	-	132,0	127,0	
40	62,5	109,5	125,0	-	-	129,5	123,0	
42	58,5	107,0	125,0	-	-	127,0	117,0	
43	-	-	123,5	-	-	124,7	110,0	
46	-	-	118,0	-	-	118,0	-	
50	-	-	108,0	-	-	110,0	-	
54	-	-	98,5	-	-	102,0	-	
56	-	-	94,5	-	-	98,0	-	
58	-	-	-	83,5	-	94,0	-	
62	-	-	-	77,0	-	85,0	-	
66	-	-	-	71,5	-	76,5	-	
68	-	-	-	69,0	-	72,7	-	
70	-	-	-	-	-	69,0	-	
72	-	-	-	-	59,0	65,5	-	
74	-	-	-	-	57,0	62,0	-	
78	-	-	-	-	53,5	55,5	-	
82	-	-	-	-	-	49,5	-	
86	-	-	-	-	-	44,6	-	
90	-	-	-	-	-	39,5	-	
94	-	-	-	-	-	34,3	-	
98	-	-	-	-	-	29,0	-	

72 m + 24 m

m	t	t	t	t	t	t	t
18	172,0	185,0	-	-	-	-	217,0
20	151,0	185,0	-	-	-	186,0	214,0
22	135,0	175,0	-	-	-	184,0	205,0
24	121,0	168,0	-	-	-	184,0	197,0
26	110,0	162,0	-	-	-	184,0	188,0
28	100,0	157,0	-	-	-	182,0	181,0
30	92,0	152,0	-	-	-	176,0	173,0
32	-	-	-	-	-	173,0	165,0
34	-	-	155,0	-	-	170,0	-
38	-	-	150,0	-	-	159,0	-
42	-	-	133,0	-	-	145,0	-
44	-	-	127,0	-	-	136,5	-
46	-	-	-	-	-	128,0	-
50	-	-	-	102,0	-	114,0	-
54	-	-	-	93,0	-	103,0	-
56	-	-	-	89,5	-	98,0	-
58	-	-	-	-	-	93,0	-
62	-	-	-	-	-	83,5	-
66	-	-	-	-	-	74,5	-
70	-	-	-	-	-	66,5	-
74	-	-	-	-	-	59,0	-
78	-	-	-	-	-	52,5	-
82	-	-	-	-	-	46,6	-
86	-	-	-	-	-	40,1	-
90	-	-	-	-	-	-	-

72 m + 48 m

m	t	t	t	t	t	t	t
25	-	-	-	-	-	-	123,0
26	104,0	106,0	-	-	-	-	123,0
28	96,5	106,0	-	-	-	106,0	120,0
30	88,0	105,0	-	-	-	106,0	118,0
34	75,0	101,0	-	-	-	106,0	113,0
38	64,5	97,0	-	-	-	106,0	107,0
42	56,5	92,0	-	-	-	106,0	102,0
46	49,9	88,0	103,0	-	-	106,0	96,5
50	44,3	84,0	101,0	-	-	101,0	91,0
54	39,6	80,0	94,0	-	-	94,0	80,0
55	-	-	92,5	-	-	92,2	75,5
58	-	-	88,0	-	-	87,0	-
62	-	-	82,0	-	-	80,5	-
64	-	-	79,0	72,0	-	78,2	-
66	-	-	76,5	69,5	-	76,0	-
70	-	-	-	64,5	-	70,5	-
74	-	-	-	60,5	-	63,5	-
78	-	-	-	56,5	-	58,0	-
82	-	-	-	-	48,5	52,0	-
86	-	-	-	-	45,6	46,9	-
90	-	-	-	-	43,0	41,9	-
94	-	-	-	-	-	38,0	-
98	-	-	-	-	-	33,6	-
102	-	-	-	-	-	29,3	-
106	-	-	-	-	-	25,1	-
110	-	-	-	-	-	20,8	-
114	-	-	-	-	-	-	-

Remarks · Bemerkungen · Remarques: see page 48 · siehe Seite 48 · voir page 48

SWSL / SFSL 15° / HSWSL

LIFTING CAPACITIES · TRAGFÄHIG-
KEITEN · CAPACITÉS DE LEVAGE

14 m x 14 m

11-15 m

360°

DIN/ISO

72 m + 60 m

72 m + 72 m

m	SWSL						SFSL	HSWSL
	0 t		0 t-250 t				t	t
	200 t	160 t	85°	85°	75°	65°		
29	-	-	-	-	-	-	93,5	
30	79,5	82,0	-	-	-	-	93,5	
34	72,5	81,0	-	-	-	82,0	90,5	
38	62,5	79,0	-	-	-	82,0	87,5	
42	54,0	76,0	-	-	-	82,0	84,0	
46	47,5	73,0	-	-	-	82,0	80,0	
50	42,0	71,0	-	-	-	82,0	76,0	
52	39,6	70,0	79,0	-	-	81,5	74,0	
54	37,3	69,0	79,0	-	-	81,0	72,0	
58	33,2	66,0	79,0	-	-	77,0	67,5	
62	29,8	64,0	77,0	-	-	72,0	63,5	
66	26,8	55,5	74,0	-	-	68,0	55,5	
67	-	-	72,5	-	-	66,8	52,5	
70	-	-	69,0	-	-	63,5	-	
72	-	-	66,0	60,0	-	62,0	-	
74	-	-	64,0	58,0	-	60,5	-	
78	-	-	60,0	54,0	-	58,0	-	
82	-	-	-	50,5	-	52,5	-	
86	-	-	-	47,8	-	47,6	-	
90	-	-	-	45,0	40,5	43,2	-	
94	-	-	-	-	38,1	38,8	-	
98	-	-	-	-	36,0	35,0	-	
102	-	-	-	-	34,0	31,2	-	
106	-	-	-	-	-	27,5	-	
110	-	-	-	-	-	24,0	-	
114	-	-	-	-	-	20,5	-	
118	-	-	-	-	-	16,9	-	
122	-	-	-	-	-	13,4	-	
126	-	-	-	-	-	-	-	
130	-	-	-	-	-	-	-	
134	-	-	-	-	-	-	-	

m	SWSL						SFSL	HSWSL
	0 t		0 t-250 t				t	t
	200 t	160 t	85°	85°	75°	65°		
33	-	-	-	-	-	-	70,0	
34	60,0	62,0	-	-	-	-	70,0	
38	59,0	62,0	-	-	-	63,0	68,5	
42	51,5	61,0	-	-	-	63,0	66,5	
46	45,0	60,0	-	-	-	63,0	64,0	
50	39,5	58,0	-	-	-	63,0	62,0	
54	34,8	56,0	-	-	-	63,0	59,5	
58	30,8	54,0	60,0	-	-	61,0	57,0	
62	27,3	53,0	60,0	-	-	59,0	55,0	
66	24,3	51,0	60,0	-	-	56,0	52,5	
70	21,7	48,0	59,0	-	-	54,0	50,5	
74	19,4	45,0	59,0	-	-	52,0	47,8	
78	17,4	40,6	58,0	-	-	49,6	40,6	
80	-	-	56,0	47,4	-	48,9	-	
82	-	-	54,0	47,4	-	48,3	-	
86	-	-	51,0	45,5	-	46,9	-	
90	-	-	45,0	42,7	-	42,7	-	
94	-	-	-	40,2	-	38,5	-	
98	-	-	-	37,9	-	35,0	-	
100	-	-	-	36,9	32,0	33,1	-	
102	-	-	-	35,9	31,1	31,4	-	
106	-	-	-	-	29,3	28,1	-	
110	-	-	-	-	27,8	24,8	-	
112	-	-	-	-	27,0	23,2	-	
114	-	-	-	-	-	21,7	-	
118	-	-	-	-	-	18,7	-	
122	-	-	-	-	-	15,8	-	
126	-	-	-	-	-	12,9	-	
130	-	-	-	-	-	9,9	-	
134	-	-	-	-	-	6,9	-	
138	-	-	-	-	-	-	-	

Remarks · Bemerkungen · Remarques

Main boom angle 85°, 75°, 65° and 55°; capacities for intermediate boom positions are calculated by the crane control system IC-1

Hauptauslegerwinkel 85°, 75°, 65° und 55°; Traglasten für Zwischenstellungen des Hauptauslegers werden von der Kransteuerung IC-1 berechnet

Jarret de flèche principale 85°, 75°, 65° et 55°; le système de commande de la grue IC-1 calcule les charges pour les positions intermédiaires de la flèche

For HSWSL a boom power-kit is required

Für HSWSL ist ein Ausleger-Verstärkungs-Kit erforderlich

Un kit à fortifier de flèche principale est nécessaire pour HSWSL

SWSL / SFSL 15° / HSWSL

LIFTING CAPACITIES · TRAGFÄHIGKEITEN · CAPACITÉS DE LEVAGE

14 m x 14 m

11-15 m

360°

DIN/ISO

72 m + 84 m

84 m + 36 m

m	SWSL					SFSL	HSWSL
	0 t		0 t-250 t			160 t	85°
	85°	85°	75°	65°	55°		
36	-	-	-	-	-	-	52,5
38	45,5	47,0	-	-	-	-	52,5
42	44,9	47,0	-	-	-	48,0	51,0
46	43,6	47,0	-	-	-	48,0	50,5
50	38,0	46,0	-	-	-	48,0	49,4
54	33,3	46,0	-	-	-	48,0	48,2
58	29,3	45,0	-	-	-	48,0	47,0
62	25,9	44,0	45,0	-	-	47,0	45,8
66	22,8	43,0	45,0	-	-	46,0	44,6
70	20,2	42,0	45,0	-	-	45,0	43,3
74	17,8	40,0	45,0	-	-	44,0	41,9
78	15,7	39,0	44,0	-	-	42,0	40,5
82	13,9	38,0	43,0	-	-	41,0	39,2
86	12,2	35,0	42,0	34,9	-	38,0	35,6
90	10,8	30,2	42,0	34,9	-	36,0	30,2
94	-	-	40,0	34,8	-	34,8	-
98	-	-	38,0	34,7	-	33,8	-
102	-	-	33,9	34,3	-	31,5	-
106	-	-	-	32,3	-	28,7	-
108	-	-	-	31,4	26,3	27,2	-
110	-	-	-	30,6	25,5	25,7	-
114	-	-	-	28,9	24,0	22,8	-
118	-	-	-	-	22,7	20,0	-
122	-	-	-	-	21,4	17,3	-
124	-	-	-	-	20,7	16,0	-
126	-	-	-	-	-	14,7	-
130	-	-	-	-	-	12,2	-
134	-	-	-	-	-	9,7	-
138	-	-	-	-	-	7,2	-
142	-	-	-	-	-	4,6	-
146	-	-	-	-	-	-	-

m	SWSL					SFSL	HSWSL
	0 t		0 t-250 t			160 t	85°
	85°	85°	75°	65°	55°		
23	-	-	-	-	-	-	129,0
24	103,0	104,0	-	-	-	105,0	129,0
26	101,0	101,0	-	-	-	105,0	125,0
28	96,0	99,0	-	-	-	104,0	122,0
30	88,0	96,0	-	-	-	104,0	118,0
34	74,5	91,0	-	-	-	104,0	111,0
38	64,5	87,0	-	-	-	103,0	105,0
42	56,5	83,0	-	-	-	102,0	99,0
44	-	-	100,0	-	-	100,5	96,0
46	-	-	100,0	-	-	99,0	-
50	-	-	95,0	-	-	92,0	-
54	-	-	90,0	-	-	86,0	-
58	-	-	86,0	-	-	81,5	-
62	-	-	-	72,5	-	77,5	-
66	-	-	-	67,0	-	71,0	-
70	-	-	-	62,5	-	64,0	-
72	-	-	-	60,0	-	60,7	-
74	-	-	-	-	-	57,5	-
78	-	-	-	-	-	52,0	-
80	-	-	-	-	47,2	49,4	-
82	-	-	-	-	45,7	46,8	-
84	-	-	-	-	44,3	44,2	-
86	-	-	-	-	-	41,8	-
90	-	-	-	-	-	37,3	-
94	-	-	-	-	-	32,9	-
98	-	-	-	-	-	28,7	-
102	-	-	-	-	-	24,6	-
106	-	-	-	-	-	20,5	-
110	-	-	-	-	-	16,4	-
114	-	-	-	-	-	-	-
118	-	-	-	-	-	-	-

Remarks · Bemerkungen · Remarques

Main boom angle 85°, 75°, 65° and 55°; capacities for intermediate boom positions are calculated by the crane control system IC-1

Hauptauslegerwinkel 85°, 75°, 65° und 55°; Traglasten für Zwischenstellungen des Hauptauslegers werden von der Kransteuerung IC-1 berechnet

Jarret de flèche principale 85°, 75°, 65° et 55°; le système de commande de la grue IC-1 calcule les charges pour les positions intermédiaires de la flèche

For HSWSL a boom power-kit is required

Für HSWSL ist ein Ausleger-Verstärkungs-Kit erforderlich

Un kit à fortifier de flèche principale est nécessaire pour HSWSL

SWSL / SFSL 15° / HSWSL

LIFTING CAPACITIES · TRAGFÄHIG-
KEITEN · CAPACITÉS DE LEVAGE

14 m x 14 m

11-15 m

360°

DIN/ISO

84 m + 48 m

84 m + 60 m

m	SWSL						SFSL	HSWSL
	0 t		0 t-250 t				t	t
	200 t	160 t						
	85°	85°	75°	65°	55°	85°		
26	79,5	80,0	-	-	-	-	100,0	
28	79,5	80,0	-	-	-	81,0	99,5	
30	78,0	79,0	-	-	-	81,0	97,5	
34	72,5	76,0	-	-	-	81,0	93,0	
38	62,5	72,0	-	-	-	81,0	88,5	
42	54,5	69,0	-	-	-	80,0	84,5	
46	48,1	66,0	-	-	-	79,0	80,5	
48	45,4	65,0	78,0	-	-	79,0	78,5	
50	42,7	64,0	78,0	-	-	79,0	76,5	
54	38,0	61,0	77,0	-	-	75,0	72,5	
56	-	-	76,0	-	-	73,0	71,0	
58	-	-	74,0	-	-	71,0	-	
62	-	-	72,0	-	-	67,0	-	
66	-	-	68,0	-	-	63,5	-	
70	-	-	65,0	60,0	-	61,5	-	
74	-	-	-	56,0	-	58,5	-	
78	-	-	-	52,5	-	53,0	-	
82	-	-	-	49,5	-	47,8	-	
84	-	-	-	48,0	-	45,6	-	
86	-	-	-	-	-	43,4	-	
88	-	-	-	-	39,3	41,1	-	
90	-	-	-	-	38,1	38,9	-	
94	-	-	-	-	36,0	34,6	-	
96	-	-	-	-	35,0	32,7	-	
98	-	-	-	-	-	30,8	-	
102	-	-	-	-	-	27,2	-	
106	-	-	-	-	-	23,7	-	
110	-	-	-	-	-	20,2	-	
114	-	-	-	-	-	16,9	-	
118	-	-	-	-	-	13,5	-	
122	-	-	-	-	-	10,0	-	

m	SWSL						SFSL	HSWSL
	0 t		0 t-250 t				t	t
	200 t	160 t						
	85°	85°	75°	65°	55°	85°		
30	61,0	64,0	-	-	-	-	77,0	
34	60,0	64,0	-	-	-	62,0	75,0	
38	58,0	62,0	-	-	-	62,0	72,5	
42	52,0	59,0	-	-	-	62,0	70,0	
46	45,8	57,0	-	-	-	62,0	67,0	
50	40,3	55,0	-	-	-	62,0	64,5	
54	35,7	52,0	60,0	-	-	62,0	61,5	
58	31,8	50,0	60,0	-	-	61,0	59,0	
62	28,4	48,0	59,0	-	-	58,0	56,5	
66	25,4	46,0	58,0	-	-	56,0	54,0	
68	-	-	57,0	-	-	54,5	52,5	
70	-	-	56,0	-	-	53,0	-	
74	-	-	54,0	-	-	51,0	-	
78	-	-	52,0	46,3	-	48,0	-	
82	-	-	49,0	45,6	-	46,0	-	
86	-	-	-	43,9	-	43,1	-	
90	-	-	-	41,6	-	38,8	-	
94	-	-	-	39,2	-	35,2	-	
96	-	-	-	38,1	-	33,2	-	
98	-	-	-	-	30,9	31,3	-	
102	-	-	-	-	29,1	27,7	-	
106	-	-	-	-	27,5	24,4	-	
108	-	-	-	-	26,8	22,8	-	
110	-	-	-	-	-	21,3	-	
114	-	-	-	-	-	18,3	-	
118	-	-	-	-	-	15,4	-	
122	-	-	-	-	-	12,6	-	
126	-	-	-	-	-	9,7	-	
130	-	-	-	-	-	6,8	-	
134	-	-	-	-	-	-	-	
138	-	-	-	-	-	-	-	

Remarks · Bemerkungen · Remarques

Main boom angle 85°, 75°, 65° and 55°; capacities for intermediate boom positions are calculated by the crane control system IC-1

Hauptauslegerwinkel 85°, 75°, 65° und 55°; Traglasten für Zwischenstellungen des Hauptauslegers werden von der Kransteuerung IC-1 berechnet

Jarret de flèche principale 85°, 75°, 65° et 55°; le système de commande de la grue IC-1 calcule les charges pour les positions intermédiaires de la flèche

For HSWSL a boom power-kit is required

Für HSWSL ist ein Ausleger-Verstärkungs-Kit erforderlich

Un kit à fortifier de flèche principale est nécessaire pour HSWSL

SWSL / SFSL 15° / HSWSL

LIFTING CAPACITIES · TRAGFÄHIG-
KEITEN · CAPACITÉS DE LEVAGE

14 m x 14 m 11-15 m 360° DIN/ISO

84 m + 72 m

		SWSL				SFSL	HSWSL
		0 t		0 t-250 t			
		200 t		160 t			
		85°	85°	75°	65°	55°	85°
m	t	t	t	t	t	t	t
34	47,2	49,0	-	-	-	-	58,5
38	46,5	49,0	-	-	-	48,0	57,5
42	45,1	48,0	-	-	-	48,0	55,5
46	43,2	47,0	-	-	-	48,0	54,0
50	37,8	45,0	-	-	-	48,0	52,5
54	33,2	44,0	-	-	-	48,0	50,5
58	29,3	42,0	-	-	-	48,0	49,0
60	27,6	41,5	47,0	-	-	48,0	48,1
62	25,9	41,0	47,0	-	-	48,0	47,2
66	23,0	39,0	46,0	-	-	46,0	45,5
70	20,4	38,0	46,0	-	-	45,0	43,7
74	18,1	37,0	45,0	-	-	44,0	42,0
78	16,1	36,0	44,0	-	-	42,0	40,3
79	-	-	43,5	-	-	41,2	39,8
82	-	-	43,0	-	-	39,0	-
84	-	-	42,0	35,3	-	37,4	-
86	-	-	41,0	35,2	-	36,0	-
90	-	-	40,0	35,0	-	35,0	-
94	-	-	39,0	34,1	-	33,1	-
98	-	-	-	33,0	-	30,1	-
102	-	-	-	31,6	-	27,1	-
106	-	-	-	30,1	24,3	24,3	-
110	-	-	-	-	22,8	21,3	-
114	-	-	-	-	21,5	18,4	-
118	-	-	-	-	20,1	15,8	-
120	-	-	-	-	19,4	14,5	-
122	-	-	-	-	-	13,2	-
126	-	-	-	-	-	10,7	-
130	-	-	-	-	-	8,3	-
134	-	-	-	-	-	5,9	-
138	-	-	-	-	-	-	-
142	-	-	-	-	-	-	-
146	-	-	-	-	-	-	-

84 m + 84 m

		SWSL				SFSL	HSWSL
		0 t		0 t-250 t			
		200 t		160 t			
		85°	85°	75°	65°	55°	85°
m	t	t	t	t	t	t	t
37	-	-	-	-	-	-	44,5
38	36,2	40,0	-	-	-	-	44,5
42	35,8	40,0	-	-	-	38,0	43,8
46	34,9	39,0	-	-	-	38,0	42,9
50	33,9	38,0	-	-	-	38,0	41,9
54	31,8	37,0	-	-	-	38,0	40,8
58	27,8	36,0	-	-	-	38,0	39,6
62	24,5	35,0	-	-	-	38,0	38,5
66	21,5	34,0	37,0	-	-	38,0	37,3
70	18,9	33,0	37,0	-	-	37,0	36,1
74	16,6	32,0	37,0	-	-	37,0	34,9
78	14,6	31,0	37,0	-	-	36,0	33,7
82	12,7	29,0	36,0	-	-	35,0	32,5
86	11,1	28,0	34,0	-	-	34,0	31,3
90	9,7	27,0	33,0	-	-	32,0	30,2
91	-	-	32,5	-	-	31,0	29,9
92	-	-	32,0	26,3	-	30,5	-
94	-	-	32,0	26,3	-	30,0	-
98	-	-	30,0	26,3	-	29,0	-
102	-	-	28,0	26,0	-	26,0	-
104	-	-	24,7	25,7	-	24,9	-
106	-	-	-	25,4	-	24,0	-
110	-	-	-	24,7	-	21,6	-
114	-	-	-	23,7	-	19,2	-
116	-	-	-	23,2	18,5	17,8	-
118	-	-	-	22,7	17,8	16,5	-
122	-	-	-	-	16,4	13,9	-
126	-	-	-	-	15,2	11,6	-
130	-	-	-	-	14,0	9,4	-
132	-	-	-	-	13,5	8,3	-
134	-	-	-	-	-	7,2	-
138	-	-	-	-	-	5,0	-
142	-	-	-	-	-	-	-

4

Remarks · Bemerkungen · Remarques

Main boom angle 85°, 75°, 65° and 55°; capacities for intermediate boom positions are calculated by the crane control system IC-1
 Hauptauslegerwinkel 85°, 75°, 65° und 55°; Traglasten für Zwischenstellungen des Hauptauslegers werden von der Kransteuerung IC-1 berechnet
 Jarret de flèche principale 85°, 75°, 65° et 55°; le système de commande de la grue IC-1 calcule les charges pour les positions intermédiaires de la flèche

For HSWSL a boom power-kit is required
 Für HSWSL ist ein Ausleger-Verstärkungs-Kit erforderlich
 Un kit à fortifier de flèche principale est nécessaire pour HSWSL

SWSL / SFSL 15° / HSWSL

LIFTING CAPACITIES · TRAGFÄHIG-
KEITEN · CAPACITÉS DE LEVAGE

14 m x 14 m

11-15 m

360°

DIN/ISO

96 m + 36 m

96 m + 48 m

m	SWSL						SFSL	HSWSL
	0 t		0 t-250 t				t	t
	85°	85°	75°	65°	55°	85°		
24	78,0	80,0	-	-	-	-	99,5	
26	77,0	80,0	-	-	-	80,0	98,0	
28	75,0	76,5	-	-	-	79,5	95,5	
30	72,5	74,0	-	-	-	78,5	92,5	
34	68,0	69,5	-	-	-	76,5	87,0	
38	62,5	65,0	-	-	-	74,5	81,5	
42	54,5	61,5	-	-	-	72,0	76,5	
45	-	-	-	-	-	70,1	73,0	
46	-	-	67,5	-	-	69,5	-	
50	-	-	65,5	-	-	66,5	-	
54	-	-	62,0	-	-	64,0	-	
58	-	-	59,0	-	-	62,0	-	
62	-	-	55,0	-	-	60,0	-	
66	-	-	-	-	-	58,0	-	
68	-	-	-	52,5	-	57,0	-	
70	-	-	-	51,5	-	56,0	-	
74	-	-	-	48,0	-	52,0	-	
78	-	-	-	44,3	-	46,8	-	
82	-	-	-	-	-	41,8	-	
86	-	-	-	-	37,1	37,6	-	
90	-	-	-	-	34,9	33,2	-	
92	-	-	-	-	34,0	31,1	-	
94	-	-	-	-	-	29,1	-	
98	-	-	-	-	-	25,3	-	
102	-	-	-	-	-	21,8	-	
106	-	-	-	-	-	18,4	-	
110	-	-	-	-	-	15,1	-	
114	-	-	-	-	-	11,9	-	
118	-	-	-	-	-	8,6	-	
122	-	-	-	-	-	-	-	
126	-	-	-	-	-	-	-	
130	-	-	-	-	-	-	-	
134	-	-	-	-	-	-	-	

m	SWSL						SFSL	HSWSL
	0 t		0 t-250 t				t	t
	85°	85°	75°	65°	55°	85°		
27	-	-	-	-	-	-	76,5	
28	60,0	60,5	-	-	-	-	76,5	
30	60,0	60,5	-	-	-	61,5	75,5	
34	56,5	57,0	-	-	-	60,0	72,0	
38	53,5	54,0	-	-	-	58,5	68,5	
42	50,0	51,0	-	-	-	57,5	65,0	
46	46,2	48,6	-	-	-	55,5	61,5	
50	40,8	46,2	-	-	-	53,5	58,5	
52	38,5	45,0	52,0	-	-	52,7	56,7	
54	36,3	43,8	52,0	-	-	52,0	55,0	
57	-	-	50,5	-	-	50,5	53,0	
58	-	-	50,0	-	-	50,0	-	
62	-	-	48,0	-	-	49,0	-	
66	-	-	46,0	-	-	47,0	-	
70	-	-	43,0	-	-	46,0	-	
74	-	-	41,0	39,9	-	44,0	-	
78	-	-	-	39,3	-	43,0	-	
82	-	-	-	36,9	-	41,0	-	
86	-	-	-	34,5	-	37,0	-	
88	-	-	-	33,3	-	35,4	-	
90	-	-	-	-	-	33,9	-	
94	-	-	-	-	-	30,2	-	
96	-	-	-	-	28,8	28,5	-	
98	-	-	-	-	28,4	26,8	-	
102	-	-	-	-	26,4	23,3	-	
104	-	-	-	-	25,4	21,6	-	
106	-	-	-	-	-	20,0	-	
110	-	-	-	-	-	17,0	-	
114	-	-	-	-	-	14,2	-	
118	-	-	-	-	-	11,4	-	
122	-	-	-	-	-	8,6	-	
126	-	-	-	-	-	5,8	-	
130	-	-	-	-	-	-	-	

Remarks · Bemerkungen · Remarques

Main boom angle 85°, 75°, 65° and 55°; capacities for intermediate boom positions are calculated by the crane control system IC-1

Hauptauslegerwinkel 85°, 75°, 65° und 55°; Traglasten für Zwischenstellungen des Hauptauslegers werden von der Kransteuerung IC-1 berechnet

Jarret de flèche principale 85°, 75°, 65° et 55°; le système de commande de la grue IC-1 calcule les charges pour les positions intermédiaires de la flèche

For HSWSL a boom power-kit is required

Für HSWSL ist ein Ausleger-Verstärkungs-Kit erforderlich

Un kit à fortifier de flèche principale est nécessaire pour HSWSL

SWSL / SFSL 15° / HSWSL

LIFTING CAPACITIES · TRAGFÄHIG-
KEITEN · CAPACITÉS DE LEVAGE

14 m x 14 m 11-15 m 360° DIN/ISO

96 m + 60 m

m	SWSL						SFSL	HSWSL
	0 t		0 t-250 t				160 t	85°
	85°	85°	75°	65°	55°			
31	-	-	-	-	-	-	60,0	
34	46,1	46,1	-	-	-	46,7	59,0	
38	43,6	44,1	-	-	-	46,0	56,5	
42	41,5	42,1	-	-	-	45,1	54,0	
46	39,4	40,1	-	-	-	44,2	51,5	
50	37,3	38,2	-	-	-	43,0	49,2	
54	34,0	36,2	-	-	-	43,0	46,8	
58	30,2	34,6	41,0	-	-	42,0	44,6	
62	26,9	33,0	41,0	-	-	41,0	42,4	
66	24,0	31,2	40,0	-	-	40,0	40,2	
69	-	-	38,5	-	-	39,2	38,6	
70	-	-	38,0	-	-	39,0	-	
74	-	-	37,0	-	-	37,0	-	
78	-	-	35,0	-	-	36,0	-	
82	-	-	33,0	29,6	-	35,0	-	
84	-	-	28,6	29,4	-	34,5	-	
86	-	-	-	29,2	-	34,0	-	
90	-	-	-	27,6	-	33,0	-	
94	-	-	-	25,9	-	30,0	-	
98	-	-	-	24,2	-	26,0	-	
100	-	-	-	23,4	-	24,5	-	
102	-	-	-	-	-	23,0	-	
104	-	-	-	-	20,4	21,6	-	
106	-	-	-	-	20,1	20,3	-	
110	-	-	-	-	19,2	17,5	-	
114	-	-	-	-	17,9	14,6	-	
118	-	-	-	-	-	12,0	-	
122	-	-	-	-	-	9,5	-	
126	-	-	-	-	-	7,1	-	
130	-	-	-	-	-	4,7	-	
134	-	-	-	-	-	-	-	

96 m + 72 m

m	SWSL						SFSL	HSWSL
	0 t		0 t-250 t				160 t	85°
	85°	85°	75°	65°	55°			
35	-	-	-	-	-	-	45,8	
38	35,4	35,4	-	-	-	36,3	45,1	
42	33,8	34,1	-	-	-	35,7	43,6	
46	32,3	32,8	-	-	-	35,0	42,0	
50	30,8	31,4	-	-	-	34,2	40,4	
54	29,2	29,9	-	-	-	33,3	38,7	
58	27,6	28,4	-	-	-	33,0	37,1	
62	24,4	27,0	-	-	-	33,0	35,5	
64	22,9	26,5	32,0	-	-	32,5	34,7	
66	21,5	26,0	32,0	-	-	32,0	34,0	
70	19,0	25,0	31,0	-	-	31,0	32,5	
74	16,8	24,0	30,0	-	-	30,0	30,9	
78	14,8	23,0	29,0	-	-	30,0	29,4	
80	-	-	29,0	-	-	29,5	28,7	
82	-	-	28,0	-	-	29,0	-	
86	-	-	27,0	-	-	28,0	-	
90	-	-	26,0	22,1	-	27,0	-	
94	-	-	25,0	21,7	-	26,0	-	
96	-	-	20,6	21,3	-	25,5	-	
98	-	-	-	20,7	-	25,0	-	
102	-	-	-	19,5	-	22,7	-	
106	-	-	-	18,3	-	19,0	-	
110	-	-	-	17,1	-	17,0	-	
112	-	-	-	16,5	-	15,7	-	
114	-	-	-	-	14,3	14,5	-	
118	-	-	-	-	13,8	11,9	-	
122	-	-	-	-	12,8	9,5	-	
126	-	-	-	-	11,8	7,1	-	
130	-	-	-	-	-	4,9	-	
134	-	-	-	-	-	-	-	
138	-	-	-	-	-	-	-	

Remarks · Bemerkungen · Remarques

Main boom angle 85°, 75°, 65° and 55°; capacities for intermediate boom positions are calculated by the crane control system IC-1

Hauptauslegerwinkel 85°, 75°, 65° und 55°; Traglasten für Zwischenstellungen des Hauptauslegers werden von der Kransteuerung IC-1 berechnet

Jarret de flèche principale 85°, 75°, 65° et 55°; le système de commande de la grue IC-1 calcule les charges pour les positions intermédiaires de la flèche

For HSWSL a boom power-kit is required

Für HSWSL ist ein Ausleger-Verstärkungs-Kit erforderlich

Un kit à fortifier de flèche principale est nécessaire pour HSWSL

SWSL / SFSL 15° / HSWSL

LIFTING CAPACITIES · TRAGFÄHIGKEITEN · CAPACITÉS DE LEVAGE

14 m x 14 m 11-15 m 360° DIN/ISO

96 m + 84 m

		SWSL				SFSL	HSWSL
		0 t		0 t-250 t			
		200 t		160 t			
		85°	85°	75°	65°	55°	85°
m	t	t	t	t	t	t	t
38	26,9	27,3	-	-	-	-	33,3
42	26,9	27,3	-	-	-	27,4	33,3
46	25,6	26,1	-	-	-	26,9	33,3
50	24,5	25,0	-	-	-	26,3	32,2
54	23,4	24,0	-	-	-	26,0	31,1
58	22,3	23,0	-	-	-	26,0	29,9
62	21,1	22,0	-	-	-	26,0	28,8
66	20,0	21,0	-	-	-	25,0	27,6
68	18,7	21,0	24,0	-	-	25,0	27,0
70	17,5	21,0	24,0	-	-	25,0	26,5
74	15,3	20,0	24,0	-	-	24,0	25,4
78	13,3	19,0	23,0	-	-	23,0	24,4
82	11,5	18,0	23,0	-	-	23,0	23,4
86	9,9	17,0	22,0	-	-	22,0	22,3
90	8,5	17,0	21,0	-	-	21,0	21,3
92	-	-	21,0	-	-	21,0	20,8
94	-	-	20,0	-	-	21,0	-
96	-	-	20,0	15,4	-	20,5	-
98	-	-	20,0	15,4	-	20,0	-
102	-	-	18,5	15,2	-	19,0	-
106	-	-	14,5	14,6	-	18,0	-
108	-	-	14,1	14,2	-	17,5	-
110	-	-	-	13,9	-	17,0	-
114	-	-	-	13,1	-	13,8	-
118	-	-	-	12,3	-	-	-
122	-	-	-	11,6	9,4	-	-
124	-	-	-	11,2	9,4	-	-
126	-	-	-	-	9,3	-	-
130	-	-	-	-	8,7	-	-
134	-	-	-	-	7,8	-	-
138	-	-	-	-	6,9	-	-

96 m + 96 m

		SWSL				SFSL	HSWSL
		0 t		0 t-250 t			
		200 t		160 t			
		85°	85°	75°	65°	55°	85°
m	t	t	t	t	t	t	t
42	19,1	19,4	-	-	-	-	-
46	19,1	19,4	-	-	-	19,6	-
50	18,2	19,0	-	-	-	19,2	-
54	17,4	18,0	-	-	-	19,0	-
58	16,6	18,0	-	-	-	19,0	-
62	15,7	17,0	-	-	-	19,0	-
66	14,9	16,0	-	-	-	19,0	-
70	14,1	16,0	-	-	-	18,0	-
74	13,2	15,0	17,0	-	-	18,0	-
78	12,4	15,0	17,0	-	-	18,0	-
82	10,7	14,0	17,0	-	-	17,0	-
86	9,0	13,0	17,0	-	-	16,0	-
90	7,6	13,0	16,0	-	-	16,0	-
94	6,2	12,0	16,0	-	-	15,0	-
98	5,0	11,0	15,0	-	-	15,0	-
101	4,1	11,0	14,7	-	-	14,2	-
102	-	11,0	14,5	-	-	14,0	-
104	-	-	14,0	9,4	-	14,0	-
106	-	-	14,0	9,4	-	14,0	-
110	-	-	13,5	9,3	-	13,0	-
114	-	-	12,5	8,9	-	13,0	-
118	-	-	8,7	8,3	-	12,0	-
120	-	-	8,3	8,1	-	11,4	-
122	-	-	-	7,8	-	10,9	-
126	-	-	-	7,3	-	-	-
130	-	-	-	6,7	4,3	-	-
134	-	-	-	6,2	4,3	-	-
136	-	-	-	5,9	4,2	-	-
138	-	-	-	-	4,0	-	-
142	-	-	-	-	-	-	-
146	-	-	-	-	-	-	-

Remarks · Bemerkungen · Remarques

Main boom angle 85°, 75°, 65° and 55°; capacities for intermediate boom positions are calculated by the crane control system IC-1
 Hauptauslegerwinkel 85°, 75°, 65° und 55°; Traglasten für Zwischenstellungen des Hauptauslegers werden von der Kransteuerung IC-1 berechnet
 Jarret de flèche principale 85°, 75°, 65° et 55°; le système de commande de la grue IC-1 calcule les charges pour les positions intermédiaires de la flèche

For HSWSL a boom power-kit is required
 Für HSWSL ist ein Ausleger-Verstärkungs-Kit erforderlich
 Un kit à fortifier de flèche principale est nécessaire pour HSWSL

SWSL / SFSL 15° / HSWSL

LIFTING CAPACITIES · TRAGFÄHIG-
KEITEN · CAPACITÉS DE LEVAGE

14 m x 14 m 11-15 m 360° DIN/ISO

108 m + 36 m

		SWSL				SFSL	HSWSL
		0 t		0 t-250 t			
		200 t		160 t			
		85°	85°	75°	65°	55°	85°
m	t	t	t	t	t	t	t
25	-	-	-	-	-	-	74,5
26	-	-	-	-	-	-	74,5
28	-	-	-	-	-	-	72,0
30	-	-	-	-	-	-	70,0
34	-	-	-	-	-	-	65,5
38	-	-	-	-	-	-	61,0
42	-	-	-	-	-	-	57,0
46	-	-	-	-	-	-	53,0
50	-	-	-	-	-	-	-

108 m + 60 m

		SWSL				SFSL	HSWSL
		0 t		0 t-250 t			
		200 t		160 t			
		85°	85°	75°	65°	55°	85°
m	t	t	t	t	t	t	t
32	-	-	-	-	-	-	43,9
34	-	-	-	-	-	-	43,9
38	-	-	-	-	-	-	41,9
42	-	-	-	-	-	-	39,8
46	-	-	-	-	-	-	37,6
50	-	-	-	-	-	-	35,5
54	-	-	-	-	-	-	33,3
58	-	-	-	-	-	-	31,6
62	-	-	-	-	-	-	29,9
66	-	-	-	-	-	-	28,2
70	-	-	-	-	-	-	26,5

108 m + 48 m

m	t	t	t	t	t	t	t
28	-	-	-	-	-	-	57,5
30	-	-	-	-	-	-	57,5
34	-	-	-	-	-	-	54,0
38	-	-	-	-	-	-	51,0
42	-	-	-	-	-	-	48,3
46	-	-	-	-	-	-	45,3
50	-	-	-	-	-	-	42,7
54	-	-	-	-	-	-	40,2
58	-	-	-	-	-	-	37,6

Remarks · Bemerkungen · Remarques

Main boom angle 85°, 75°, 65° and 55°; capacities for intermediate boom positions are calculated by the crane control system IC-1
 Hauptauslegerwinkel 85°, 75°, 65° und 55°; Traglasten für Zwischenstellungen des Hauptauslegers werden von der Kransteuerung IC-1 berechnet
 Jarret de flèche principale 85°, 75°, 65° et 55°; le système de commande de la grue IC-1 calcule les charges pour les positions intermédiaires de la flèche

For HSWSL a boom power-kit is required

Für HSWSL ist ein Ausleger-Verstärkungs-Kit erforderlich

Un kit à fortifier de flèche principale est nécessaire pour HSWSL

TEREX DEMAG TC 2800-1

AUTOJEŘÁB

// Tomáš Novotný
AUTOJEŘÁBY DEMOLICE s.r.o.

SFVL / LFVL WORKING RANGES · ARBEITSBEREICHE ·
PORTÉES

13°

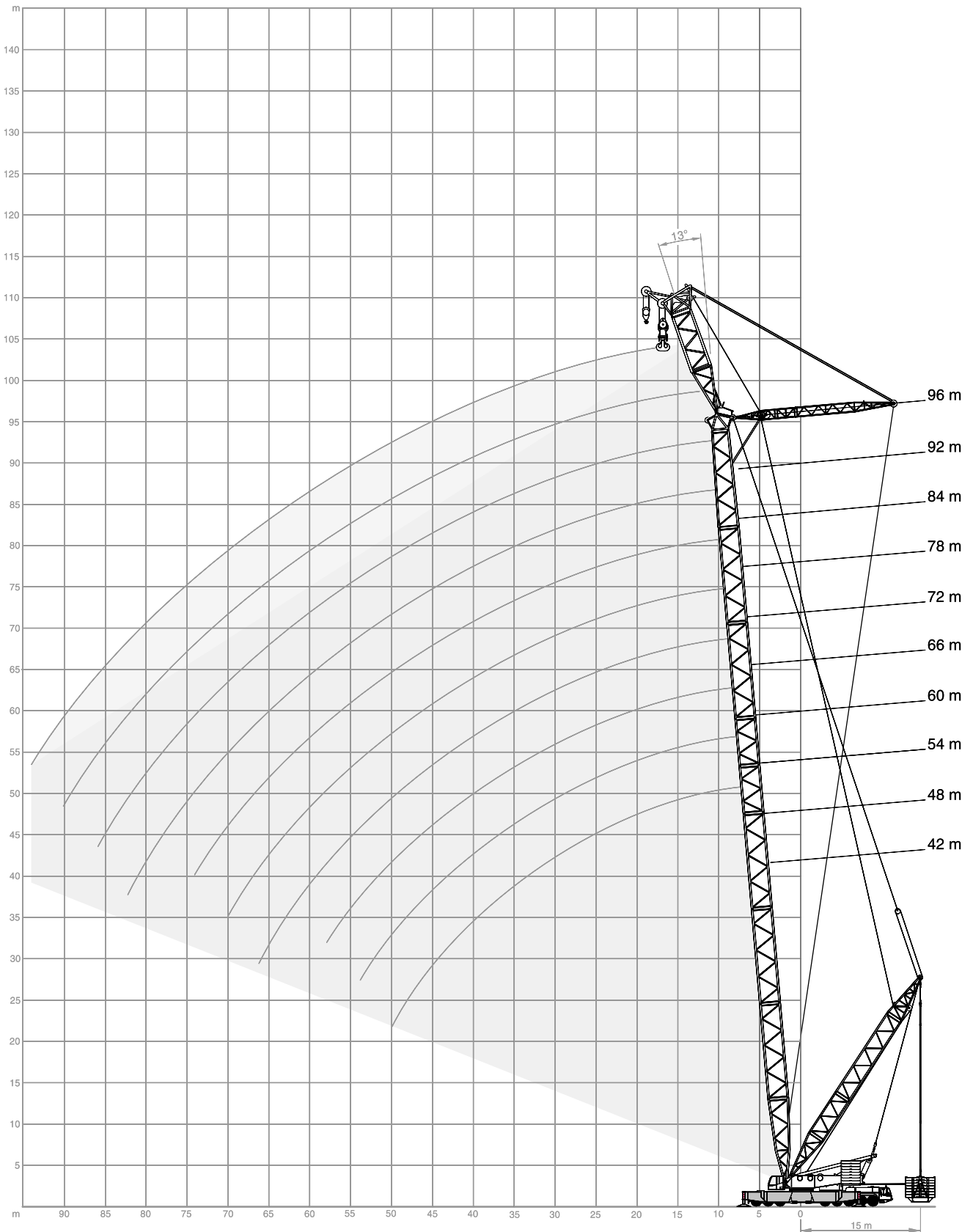

TEREX DEMAG TC 2800-1

AUTOJEŘÁB

//Tomáš Novotný
AUTOJEŘÁBY DEMOLICE s.r.o.

SFVL / LFVL LIFTING CAPACITIES · TRAGFÄHIGKEITEN · CAPACITÉS DE LEVAGE

160 t 11-15 m 0-300 t 12 m 14 m x 14 m 360° DIN/ISO

m	42 m			48 m			54 m			60 m		
	SFVL		LFVL	SFVL		LFVL	SFVL		LFVL	SFVL		LFVL
	13°	20°	17,5°	13°	20°	17,5°	13°	20°	17,5°	13°	20°	17,5°
	t	t	t	t	t	t	t	t	t	t	t	t
12	480,0	-	-	430,0	-	-	-	-	-	-	-	-
13	469,0	-	300,0	429,0	-	300,0	-	-	300,0	-	-	-
14	458,0	438,0	300,0	428,0	412,0	300,0	387,0	369,0	300,0	350,0	-	300,0
16	419,0	418,0	300,0	417,0	401,0	300,0	385,0	369,0	300,0	348,0	334,0	300,0
18	380,0	381,0	300,0	377,0	378,0	300,0	375,0	366,0	300,0	346,0	329,0	300,0
20	347,0	347,0	300,0	344,0	345,0	300,0	342,0	343,0	300,0	339,0	324,0	300,0
22	317,0	318,0	291,0	315,0	316,0	296,0	313,0	314,0	300,0	311,0	310,0	300,0
24	286,0	287,0	269,0	284,0	285,0	280,0	282,0	283,0	278,0	280,0	281,0	282,0
26	260,0	261,0	249,0	262,0	262,0	260,0	261,0	260,0	261,0	254,0	256,0	259,0
28	239,0	239,0	230,0	242,0	242,0	240,0	240,0	241,0	240,0	237,0	238,0	238,0
30	220,0	221,0	212,0	223,0	223,0	221,0	222,0	222,0	222,0	219,0	220,0	220,0
34	189,0	190,0	180,0	190,0	191,0	188,0	189,0	190,0	192,0	188,0	188,0	190,0
38	160,0	163,0	152,0	163,0	163,0	160,0	164,0	165,0	165,0	163,0	163,0	166,0
42	137,0	138,0	131,0	143,0	142,0	137,0	142,0	142,0	144,0	143,0	143,0	145,0
46	113,0	114,0	115,0	123,0	124,0	119,0	128,0	128,0	125,0	127,0	127,0	126,0
50	92,0	-	97,5	104,0	104,0	105,0	110,0	111,0	108,0	113,0	113,0	112,0
54	-	-	-	86,0	-	91,5	94,5	95,0	96,0	98,0	98,5	99,0
58	-	-	-	-	-	-	79,5	80,0	85,0	84,5	85,0	87,0
62	-	-	-	-	-	-	-	-	-	72,0	72,5	77,5
66	-	-	-	-	-	-	-	-	-	60,0	-	-
70	-	-	-	-	-	-	-	-	-	-	-	-

m	66 m			72 m			78 m			84 m		
	SFVL		LFVL	SFVL		LFVL	SFVL		LFVL	SFVL		LFVL
	13°	20°	17,5°	13°	20°	17,5°	13°	20°	17,5°	13°	20°	17,5°
	t	t	t	t	t	t	t	t	t	t	t	t
14	297,0	-	277,0	-	-	-	-	-	-	-	-	-
15	296,0	-	277,0	259,0	-	-	-	-	-	-	-	-
16	295,0	284,0	277,0	259,0	252,0	245,0	219,0	211,0	205,0	194,0	-	181,0
18	293,0	282,0	277,0	258,0	250,0	245,0	217,0	211,0	205,0	192,0	187,0	181,0
20	291,0	280,0	277,0	257,0	249,0	245,0	215,0	209,0	205,0	190,0	185,0	181,0
22	282,0	277,0	275,0	254,0	247,0	245,0	213,0	207,0	205,0	189,0	183,0	181,0
24	270,0	267,0	262,0	246,0	242,0	240,0	211,0	205,0	204,0	186,0	182,0	181,0
26	253,0	254,0	249,0	239,0	235,0	232,0	208,0	203,0	202,0	183,0	179,0	179,0
28	231,0	232,0	236,0	229,0	229,0	224,0	205,0	200,0	199,0	179,0	176,0	177,0
30	218,0	216,0	218,0	210,0	211,0	215,0	202,0	197,0	197,0	176,0	172,0	175,0
34	187,0	187,0	188,0	185,0	182,0	185,0	178,0	179,0	184,0	165,0	164,0	168,0
38	161,0	162,0	164,0	160,0	160,0	162,0	154,0	155,0	158,0	149,0	149,0	154,0
42	141,0	142,0	144,0	140,0	140,0	142,0	135,0	135,0	138,0	132,0	133,0	136,0
46	125,0	125,0	128,0	123,0	124,0	126,0	122,0	122,0	122,0	116,0	117,0	120,0
50	112,0	112,0	112,0	110,0	110,0	112,0	108,0	108,0	110,0	104,0	104,0	107,0
54	99,5	100,0	100,0	98,0	98,5	100,0	95,5	96,0	99,0	92,0	92,5	96,5
58	87,0	87,5	90,0	86,5	87,0	89,0	85,0	85,5	89,0	82,0	82,0	86,5
62	75,5	76,0	80,0	76,0	76,5	80,0	75,0	75,5	80,5	73,0	73,5	78,0
66	65,0	65,0	70,0	66,0	66,5	71,5	66,0	66,5	71,5	64,5	65,0	70,0
70	54,5	-	60,0	57,0	57,5	62,5	58,0	58,0	63,5	57,0	57,0	62,0
74	-	-	-	48,7	-	53,5	50,0	50,5	55,5	49,8	50,0	55,0
78	-	-	-	-	-	-	42,9	43,1	48,1	43,0	43,3	48,3
82	-	-	-	-	-	-	35,5	-	-	36,6	36,8	41,8
86	-	-	-	-	-	-	-	-	-	30,3	-	-
90	-	-	-	-	-	-	-	-	-	-	-	-

5

TEREX DEMAG TC 2800-1

AUTOJEŘÁB

//Tomáš Novotný
AUTOJEŘÁBY DEMOLICE s.r.o.

SFVL / LFVL LIFTING CAPACITIES · TRAGFÄHIGKEITEN ·
CAPACITÉS DE LEVAGE

160 t 11-15 m 0-300 t 12 m 14 m x 14 m 360° DIN/ISO

m	90 m			96 m			
	SFVL		LFVL	SFVL		LFVL	
	13°	20°	17,5°	13°	20°	17,5°	
t	t	t	t	t	t		
16	145,0	-	-	-	-	-	
17	145,0	-	145,0	128,0	-	129,0	
18	145,0	141,0	145,0	128,0	124,0	129,0	
20	142,0	139,0	142,0	125,0	124,0	127,0	
22	142,0	138,0	140,0	123,0	121,0	124,0	
24	142,0	138,0	137,0	122,0	119,0	122,0	
26	142,0	138,0	134,0	122,0	119,0	119,0	
28	140,0	137,0	132,0	121,0	119,0	116,0	
30	139,0	135,0	129,0	119,0	117,0	114,0	
34	135,0	132,0	123,0	116,0	114,0	108,0	
38	129,0	127,0	117,0	112,0	110,0	102,0	
42	123,0	121,0	111,0	108,0	106,0	97,5	
46	108,0	108,0	105,0	103,0	101,0	92,0	
50	97,5	96,5	99,0	93,0	94,0	87,0	
54	88,5	89,0	92,5	82,0	83,0	82,0	
58	79,0	79,0	84,5	75,0	75,0	77,0	
62	70,5	71,0	76,0	66,5	67,0	72,0	
66	62,5	63,0	68,0	59,5	59,5	65,0	
70	55,0	55,5	60,5	52,5	53,0	58,0	
74	48,6	48,9	54,0	46,3	46,6	51,5	
78	42,3	42,6	47,7	40,4	40,7	45,9	
82	36,4	36,7	41,7	34,9	35,2	40,3	
86	30,8	31,0	36,0	29,8	30,0	35,1	
90	25,3	-	30,5	24,8	25,0	30,0	
94	-	-	-	20,0	-	25,1	

KEY · ZEICHENERKLÄRUNG · LÉGENDE

- 
Outrigger base · Stützbasis · Basis de calage

- 
Counterweight · Gegengewicht · Contrepoids

- 
Superlift counterweight · Superlift-Gegengewicht · Contrepoids Superlift

- 
Superlift radius · Superlift-Radius · rayon Superlift

- 
Load radius · Lastradius · Portée

- 
Main boom · Hauptausleger · Flèche principale

- 
Fly jib · Hilfsausleger · Fléchette

- 
Main boom angle · Hauptauslegerwinkel · Jarret de flèche principale

- 
Fly jib angle · Hilfsauslegerwinkel · Jarret de fléchette

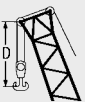
- 
„D“

- S:
heavy · schwer · lourd

- L:
light · leicht · léger

- H:
Main boom · Hauptausleger · Flèche principale

- W:
Luffing fly jib · Wippbarer Hilfsausleger · Fléchette à volée variable

- F:
Fixed fly jib · Starrer Hilfsausleger · Fléchette fixe

- SL:
Superlift

- SGL:
Heavy base length · Schwere Grundlänge · Longueur de base lourde

TECHNICAL DESCRIPTION

CARRIER

Drive / Steering	16 x 8 x 16.
Frame	In-plant built special main frame of high-strength fine-grain structural steel, with pot-shaped centre section to accommodate the outrigger beams.
Outriggers	4-point outrigger system, 4 outrigger beams, fully hydraulic horizontal and vertical extension, providing 360° continuous rotation. Outrigger loading indicator. Outrigger base 14 x 14 m and 10 x 10 m. Outriggers with hydraulic pin-connections to facilitate disassembly for transportation.
Engine	Water-cooled 8-cylinder DaimlerChrysler diesel engine OM 502 LA, output 482 kW (646 hp) at 1800 1/min, torque 2820 Nm at 1300 1/min. The engine complies with EUROMOT 3a, EPA T3 and Carb regulations.
Transmission	ZF-TC-Tronic, automatical transmission with torque converter and hydraulic retarder, 12 forward speeds and 2 reverse.
Axles	3 + 4, 6 + 7 driving, all axles steering, hydropneumatically suspended and hydraulically blockable.
Wheels and tyres	16 wheels, 14.00 R 25.
Steering	Dual-circuit semiblock mechanical steering with hydraulic booster.
Brakes	In conformity with EC-directives. Sustained action brake: constant decompression valve, exhaust brake, hydraulic retarder integrated into gearbox.
Electrical equipment	24 V system, lighting in compliance with German StVZO and EC regulations.
Driver's cab	Rubber-mounted low-line steel cab, ergonomic design, with pneumatically suspended driver's seat and one passenger's seat; vertically adjustable steering wheel; heated outside mirrors, right-hand mirror electrically adjustable; dashboard with clearly arranged instrumentation and carrier controls.

SUPERSTRUCTURE

Counterweight	160 t.
Frame	Torsion-resistant welded structure fabricated of high-strength fine-grain structural steel. Connected to carrier by triple-row roller bearing slew ring.
Drive	DaimlerChrysler diesel engine type OM 502 LA, 390 kW (530 hp) at 1800 1/min, torque 2400 Nm at 1300 1/min. The engine complies with EUROMOT 3a, EPA T3 and Carb regulations. Pump distribution gearbox with five variable displacement axial piston pumps, and gear pumps. Silencer with spark-arrestor.
Rope drums	The standard superstructure equipment includes three rope drums – hoist 1, hoist 2 and boom hoist. The drums are powered by hydraulic motors through closed planetary gear units running in oil bath. All rope drums have spring-applied, hydraulically released multi-disk brakes and non-wearing hydraulic braking for load lowering. Rope ends H 1, 2, 3 and W 1, 2 equipped with quick-connect rope end fittings. Hoists H 1 + 2 are removable to minimise weight for transportation.
A-frame	Hydraulic raising system for A-frame as standard.
Slew unit	Powered by hydraulic motor through closed, planetary gear unit running in oil bath. Spring-applied, hydraulically released holding brake and non-wearing hydraulic braking.
Control system	Demag IC-1: Electronic proportional valve pilot control integrated in stored-program control system incl. diagnostics. 2 colour monitors, safe load indicator operated via a touchscreen. Working speeds infinitely variable controlled by the lever position. Automatic power control for optimal utilisation of engine output, wireless emergency control system.
Cabin	Comfortable cab with large windscreen and airconditioner. Safety-glazing all around, roof window, self-contained hot air heater, full instrumentation and crane controls. The cab can be tilted back for improved operator view of boom point. A camera system is installed to monitor the rope drums. For transportation, the cab swings in front of the superstructure to minimise width.
Electrical equipment	24 V d. c. system (2 x batteries 12 V, 200 Ah).

OPTIONAL EQUIPMENT

Counterweight	40 t on superstructure 7.5 t counterweights casted counterweights
Support wheels	For on-site travel with attachments and partial counterweight.
Wheels and tyres	Wide tyres 17.00 R 25 optionally available, carrier width with these tyres 3.15 m.
Independent rear axle steering	
Spare wheel with mount	
Air conditioner	On the carrier.

TECHNICAL DESCRIPTION

BOOM CONFIGURATIONS S AND L

SH:	Main boom: foot section 10.5 m (used to install drums W1/H3), inserts 12 m and 6 m (type 2724) and tapered insert 12 m, head with sheave assembly 600 t 1.5 m. Main boom lengths: 24-84 m.
SH / LH:	Main boom: same as SH, extended by type 2421 from the fly jib and by top section 7.5 m. Main boom lengths: 66-102 m.
SW:	Main boom: same as SH. Fly jib: foot section 4.5 m, inserts 12 m and 6 m (type 2421) and top section 7.5 m. Main boom lengths: 30-66 m. Fly jib lengths: 24-84 m.
SSL:	Main boom: same as SH. Superlift equipment, Superlift counterweight 0-300 t (at 50 t increments). Main boom lengths: 36-96 m.
HSSL:	Main Boom: same as SH/SSL + boom power-kit. Superlift equipment, Superlift counterweight 0-300 t (at 50 t increments). Main boom lengths: 54-108 m.
SSL / LSL:	Main boom: same as SH 84 m, extended by type 2421 from the fly jib and by top section 7.5 m. Superlift equipment, Superlift counterweight 0-300 t (at 50 t increments). Main boom lengths: 90-138 m.
SWSL: (SFSL)	Main boom: same as SH. Fly jib: same as SW. Superlift equipment, Superlift counterweight 0-300 t (at 50 t increments). Main boom lengths: 36-96 m. Fly jib lengths: 24-96 m.
HSWSL:	Main Boom: same as HSSL. Fly jib: same as SW/SWSL. Superlift equipment, Superlift counterweight 0-300 t (at 50 t increments). Main boom lengths: 54-108 m. Fly jib lengths: 24-96 m.
LF2:	Main boom: same as SH, SSL, HSSL, SH/LH, SH/LH SGLmax; SSL/LSL, SSL/LSL SGLmax. Fly jib lengths: 12, 24, 36 m. Fly jib offsets: 10°, 15°, 20° for jib length 12 m. Fly jib offsets: 10°, 20°, 30° for jib lengths 24-36 m.
SFVL:	Main boom: same as SH, lengths 42-96 m, without sheave assembly. Fly jib: foot section 4.5 m, insert 6 m; heavy-duty head 1.5 m. Sheave assembly 600 t same as SH.
LFVL:	Main boom: same as SH, lengths 42-96 m, without sheave assembly. Fly jib: foot section 4.5 m, jib top section 7.5 m.
SH / LH SGLmax:	Same as SH, extended by boom power-kit + jib top section. Main boom lengths: 78-102 m.
SSL / LSL SGLmax:	Same as SSL, extended by boom power-kit + jib top section. Main boom lengths: 90-138 m.
Reeving winch	Mounted on superstructure.
Operator aids	Electronic safe load indicator, hoist limit switch, limit switches for boom movements, hydraulic boom backstops, anemometer.

OPTIONAL EQUIPMENT

Power-kit for main boom	Consisting of 2-4 additional heavy main boom sections; standard main boom 84 m required.
Superlift equipment standard	Mast 30 m, winch with rope and tray for 300 t. Mast radii 11, 13 and 15 m by adjusting the Superlift mast.
Superlift equipment with telescopic cylinder	Mast 30 m, winch with rope, SL telescopic cylinder and tray for 300 t. Mast position 15 m. Superlift counterweight can be adjusted from 13 to 17 m.
Hoist H3	Additional rope drum on main boom (for LF2 or runner operation). Line pull same as H1, rope length 650 m.
Runner 30 t	Approx. 2 m for installation on boom head or top section (not in conjunction with LF2).
Runner 60 t	
Hydraulic pinning of boom sections	
W1 as H3	Optional utilisation of the W1 luffing jib as a H3 hoist system.

TECHNISCHE BESCHREIBUNG

UNTERWAGEN

Antrieb / Lenkung	16 x 8 x 16.
Rahmen	Eigengefertigter Spezialträgerahmen aus hochfestem Feinkornbaustahl, mit zentralem Topf zur Aufnahme der Stützträger.
Abstützung	4-Punkt-Abstützung, 4 Stützträger, vollhydraulisch horizontal und vertikal ausfahrbar, für 360° Arbeitsbereich. Stützkraftanzeige. Stützbasis 14 x 14 m und 10 x 10 m. Stützen sind hydraulisch angebolzt und separat zu transportieren.
Motor	Wassergekühlter 8-Zylinder DaimlerChrysler Dieselmotor OM 502 LA, Leistung: 482 kW (646 PS) bei 1800 1/min, Drehmoment 2820 Nm bei 1300 1/min. Der Motor erfüllt EUROMOT 3a, EPA T3 und Carb-Vorschriften.
Getriebe	ZF-TC-Tronic, automatisiert. Drehmomentwandler und hydraulischer Retarder, 12 Vorwärts- und 2 Rückwärtsgänge.
Achsen	3. + 4., 6. + 7. Achse angetrieben, alle Achsen gelenkt, alle Achsen hydropneumatisch gefedert und hydraulisch blockierbar.
Bereifung	16-fach, 14.00 R 25.
Lenkung	2-Kreis-Hydro-Halblocklenkung.
Bremsen	Nach EG-Richtlinien; Dauerbremse: Konstantdrossel, Auspuffklappenbremse, hydraulischer Retarder im Getriebe.
Elektrische Anlage	Betriebsspannung 24 Volt, Beleuchtung nach StVZO und EG-Richtlinie.
Fahrerkabine	Elastisch gelagerte Low-Line-Kabine aus Stahlblech, ergonomisch gestaltet, mit einem pneumatisch gefederten Fahrersitz und einem Beifahrersitz; höhenverstellbarem Lenkrad; beheizbare Außenspiegel, rechts elektrisch verstellbar; übersichtliches Armaturenbrett mit allen erforderlichen Bedien- und Kontrollelementen.

OBERWAGEN

Gegengewicht	160 t.
Rahmen	Verformungssteife Schweißkonstruktion aus hochfestem Feinkornbaustahl. Verbindung zum Unterwagen durch 3-reihige Rollendrehverbindung.
Antrieb	DaimlerChrysler Dieselmotor Typ OM 502 LA, 390 kW (530 PS) bei 1800 1/min, Drehmoment 2400 Nm bei 1300 1/min. Der Motor erfüllt EUROMOT 3a, EPA T3 und Carb-Vorschriften. Pumpenverteilergetriebe mit fünf verstellbaren Axialkolbenpumpen und zusätzlichen Zahnradpumpen. Schalldämpfer mit Funkenfänger.
Seilwinden	Der Oberwagen ist serienmäßig mit drei Seilwinden – Hubwerk 1, Hubwerk 2 und Einziehwerk – ausgerüstet. Der Antrieb der Winden erfolgt durch Hydromotoren über geschlossene, ölbadgeschmierte Planetengetriebe. Alle Seilwinden sind mit federbelasteten, hydraulisch gelüfteten Lamellenbremsen und verschleißfreier, hydraulischer Bremsung für den Senkvorgang ausgerüstet. Die Seilenden H 1, 2, 3 und W 1, 2 sind mit Preßfitting und Taschen ausgestattet. Zur Reduzierung der Transportgewichte sind die Winden H 1 + 2 ausbaubar.
A-Bock	Hydraulische A-Bock-Umlage serienmäßig.
Drehwerk	Ein Drehwerk mit Antrieb durch Hydromotor über geschlossenes, ölbadgeschmiertes Planetengetriebe. Federbelastete, hydraulisch gelüftete Haltebremse und verschleißfreie hydraulische Bremsung.
Steuerung	Demag IC-1: Elektronische Proportionalventilvorsteuerung integriert in eine speicherprogrammierte Steuerung mit Fehlerdiagnose. Zwei Farbbildschirme, Bedienung über Touchscreen. Die Arbeitsgeschwindigkeiten werden durch die Hebelstellung stufenlos geregelt. Leistungsregelung der Antriebe zur optimalen Nutzung der Motorleistung, drahtlose Notsteuerung.
Kabine	Komfortkabine mit großem Frontfenster und Klimaanlage. Sicherheitsverglasung rundum, Dachfenster, motorunabhängige Warmluftheizung und Steuer- und Kontrollelementen für die Kranfunktionen. Die Kabine ist zur Sichtverbesserung nach hinten neigbar. Zur Überwachung der Winden im Oberwagen ist ein Kamerasystem installiert. Während des Transportes ist die Kabine vor den Oberwagen geschwenkt.
Elektrische Anlage	24 V Gleichstrom (2 x Batterie 12 V, 200 Ah).

ZUSATZAUSRÜSTUNG

Gegengewicht	40 t am Oberwagen 7,5 t Gegengewichte Gegengewichte aus Guss
Stützräder	Zum Verfahren auf der Baustelle mit Einrichtung und Teilgegengewicht.
Bereifung	Breitreifen 17.00 R 25 erhältlich. Breite des Unterwagens mit Breitreifen: 3,15 m.
Unabhängige Hinterachslenkung	
Reserverad und Halterung	
Klimaanlage	Am Unterwagen.

TECHNISCHE BESCHREIBUNG

AUSLEGERVARIANTEN S UND L

SH:	Hauptausleger: Fußstück 10,5 m (geeignet zum Einbau der Winde W1/H3), Zwischenstücke 12 m und 6 m (Typ 2724) und Reduzierstück 12 m, Kopf mit Rollensatz 600 t 1,5 m. Hauptauslegerlängen: 24-84 m.
SH / LH:	Hauptausleger: wie SH, verlängert mit Typ 2421 aus Hilfsausleger und Spitze 7,5 m. Hauptauslegerlängen: 66-102 m.
SW:	Hauptausleger: wie SH. Hilfsausleger: Fußstück 4,5 m, Zwischenstücke 12 m und 6 m (Typ 2421) und Spitze 7,5 m. Hauptauslegerlängen: 30-66 m. Hilfsauslegerlängen: 24-84 m.
SSL:	Hauptausleger: wie SH. Superlift-Einrichtung, Superliftgegengewicht 0-300 t (Stufung 50 t). Hauptauslegerlängen: 36-96 m.
HSSL:	Hauptausleger: wie SH/SSL + Hauptausleger-Verstärkungs-Kit. Superlift-Einrichtung, Superliftgegengewicht 0-300 t (Stufung 50 t). Hauptauslegerlängen: 54-108 m.
SSL / LSL:	Hauptausleger: wie SH 84 m, verlängert mit Typ 2421 aus Hilfsausleger und Spitze 7,5 m. Superlift-Einrichtung, Superliftgegengewicht 0-300 t (Stufung 50 t). Hauptauslegerlängen: 90-138 m.
SWSL: (SFSL)	Hauptausleger: wie SH. Hilfsausleger: wie SW. Superlift-Einrichtung, Superliftgegengewicht 0-300 t (Stufung 50 t). Hauptauslegerlängen: 36-96 m. Hilfsauslegerlängen: 24-96 m.
HSWSL:	Hauptausleger: wie HSSL. Hilfsausleger: wie SW/SWSL. Superlift-Einrichtung, Superliftgegengewicht 0-300 t (Stufung 50 t). Hauptauslegerlängen: 54-108 m. Hilfsauslegerlängen: 24-96 m.
LF2:	Hauptausleger: wie SH, SSL, HSSL, SH/LH, SH/LH SGLmax; SSL/LSL, SSL/LSL SGLmax. Hilfsauslegerlängen: 12, 24, 36 m. Hilfsausleger-Vorneigung: 10°, 15°, 20° für Hilfsauslegerlänge 12 m. Hilfsausleger-Vorneigung: 10°, 20°, 30° für Hilfsauslegerlängen 24-36 m.
SFVL:	Hauptausleger: wie SH, Längen 42-96 m, ohne Rollensatz. Hilfsausleger: Fußstück 4,5 m, Zwischenstück 6 m; Schwerlastkopf 1,5 m. Rollensatz 600 t wie SH.
LFVL:	Hauptausleger: wie SH, Längen 42-96 m, ohne Rollensatz. Hilfsausleger: Fußstück 4,5 m, Hilfsausleger-Spitze 7,5 m.
SH / LH SGLmax:	Wie SH, verlängert um Hauptausleger-Verstärkungs-Kit + Hilfsausleger-Spitze. Hauptauslegerlängen: 78-102 m.
SSL / LSL SGLmax:	Wie SSL, verlängert um Hauptausleger-Verstärkungs-Kit + Hilfsausleger-Spitze. Hauptauslegerlängen: 90-138 m.
Einscherwinde	Auf Oberwagen angebaut.
Sicherheitseinrichtungen	Elektronischer Lastmomentbegrenzer, Hubendschalter, Endschalter für Auslegerbewegungen, hydraulische Ausleger-Rückfallsicherungen, Windmesser.

ZUSATZAUSRÜSTUNG

Hauptausleger-Verstärkungs-Kit	Bestehend aus 2-4 zusätzlichen schweren Hauptauslegerstücken; Standard-Hauptausleger 84 m erforderlich.
Superlift-Einrichtung Standard	Mast 30 m, Winde mit Seil und Traverse für 300 t. Mastradien 11, 13 und 15 m, durch Verstellung der Mastposition.
Superlift-Einrichtung Teleskopverstellung	Mast 30 m, Winde mit Seil, Teleskopverbindung und Traverse für 300 t. Maststellung 15 m. Superlift-Gegengewicht verstellbar von 13 bis 17 m.
Seilwinde H3	Zusätzliche Seilwinde im Hauptausleger (zum Betrieb an LF2 oder Runner). Seilzug wie H1, Seillänge 650 m.
Runner 30 t	Ca. 2 m zum Anbau an Kopf oder Spitze (nicht in Verbindung mit LF2).
Runner 60 t	
Auslegerteile hydraulisch verbolzbar	
W1 als H3	Option zur Verwendung des Wippwerks W1 als Hubwerk H3.

DESCRIPTIF TECHNIQUE

CHÂSSIS

Entraînement / direction	16 x 8 x 16.
Cadre-châssis	Cadre-châssis spécial fabriqué dans nos usines, réalisé en tôle d'acier de construction de haute résistance à grains fins, avec partie centrale cylindrique recevant les poutres de calage.
Calage	Calage de quatre points, constitué de quatre poutres, extractibles hydrauliquement sur un plan horizontal et de quatre vérins verticaux, permettant une orientation sur 360° en continu. Indicateur de force de calage. Bases de calage 14 x 14 m et 10 x 10 m. Poutres de calage à brochage hydraulique facilitant le démontage pour le transport.
Moteur	DaimlerChrysler diesel OM 502 LA, 8 cylindres, refroidi par eau, puissance 482 kW (646 CV) à 1800 1/min, couple 2820 Nm à 1300 1/min. Le moteur satisfait aux réglemens EUROMOT 3a, EPA T3 et Carb.
Transmission	ZF-TC-Tronic, transmission automatique avec convertisseur de couple et ralentisseur hydraulique, 12 vitesses AV et 2 AR.
Essieux	3 + 4, 6 + 7 moteurs, tous les essieux sont directeurs avec suspension hydro-pneumatique et blocage hydraulique.
Pneumatiques	16 pneus, 14.00 R 25.
Direction	Direction à servo-commande hydraulique, du type demi-bloc, à double circuit.
Freinage	Selon normes CE. Frein continu: soupape d'étranglement, frein sur échappement, ralentisseur hydraulique intégré à la transmission.
Installation électrique	Système 24 V, éclairage selon normes StVZO et CE.
Cabine châssis	Cabine surbaissée en tôle d'acier, à suspension élastique, conception ergonomique, siège conducteur à suspension pneumatique et un siège passager; volant réglable en hauteur; rétroviseurs extérieurs dégivrants, réglable électriquement celui-ci du côté droit; tableau de bord clair et lisible comprenant les manettes de commande et les indicateurs de contrôle.

PARTIE SUPÉRIEURE

Contrepoids	160 t.
Charpente	Structure mécano-soudée, rigide à la torsion, réalisée en acier de construction de haute résistance à grains fins. Couronne d'orientation à trois rangées de rouleaux servant de jonction entre la partie tournante et le châssis.
Moteur et transmission	Moteur diesel DaimlerChrysler, type OM 502 LA, 390 kW (530 CV) à 1800 1/min, couple 2400 Nm à 1300 1/min. Le moteur satisfait aux réglemens EUROMOT 3a, EPA T3 et Carb. Boîte de distribution à cinq pompes hydrauliques à débit variable du type à pistons axiaux ainsi que pompes à engrenages. Dispositif d'échappe avec pare-étincelles.
Tambours	L'équipement standard de la partie tournante comprend trois tambours – treuil no 1, treuil no 2 et mécanisme de relevage. Les tambours sont entraînés par des moteurs hydrauliques munis de réducteurs planétaires, sous bain d'huile, en carter étanche. Tous les tambours sont munis de freins à disques multiples, à commande par ressorts, et desserrés hydrauliquement. Freinage anti-usure hydraulique pour descendre la charge. Les pattes de câble H 1, 2, 3 et W 1, 2 sont équipées des attaches à jonction rapide. Treuils H 1 + 2 sont démontables pour diminuer le poids de transport.
Chevalet	Système de relevage hydraulique pour chevalet en serie.
Mécanisme d'orientation	Entraîné par moteur hydraulique avec réducteur planétaire, sous bain d'huile, en carter étanche. Frein d'arrêt à commande par ressorts, desserré hydrauliquement ainsi que freinage anti-usure hydraulique.
Commande	Demag IC-1 : Pilotage électronique de soupapes proportionnelles intégré dans un automate programmable avec diagnostic de dysfonctionnement. 2 écrans couleur, commande du C.E.C. par écran tactile. Les vitesses de travail sont réglées sans paliers par la position du levier. Régulation automatique pour une exploitation optimale de la puissance du moteur, commande d'urgence sans fil.
Cabine	Cabine confortable avec large pare-brise et climatisation. Vitrage de sécurité, fenêtre de toit, chauffage à air autonome, organes de commande et instruments de contrôle. Cabine inclinable en arrière assurant au grutier une visibilité optimale. Une caméra est installée pour la surveillance des treuils. Pendant le transport, la cabine est basculée à l'avant de la partie tournante.
Installation électrique	24 V courant continu (2 x accumulateurs 12 V, 200 Ah).

EQUIPEMENTS OPTIONNELS

Contrepoids	40 t sur la partie supérieure contrepoids 7,5 t contrepoids en fonte
Roues de support	Utilisées lors de déplacements sur site avec équipements et contrepoids partiel.
Pneumatiques	Pneus larges 17.00 R 25 disponibles. Largeur du châssis avec ces pneus: 3,15 m.
Commande séparée des essieux AR	
Roue de secours avec support	
Climatisation	Sur le châssis.

DESCRIPTIF TECHNIQUE

CONFIGURATIONS DE FLÈCHE S ET L

SH:	Flèche principale: pied 10,5 m (utilisé à installer treuils W1/H3), intercalaires 12 m et 6 m (type 2724) et tronçon conique 12 m, tête avec jeu de poulies 600 t 1,5 m. Longueurs de flèche principale: 24-84 m.
SH / LH:	Flèche principale: idem SH, allongée par type 2421 de la fléchette et par l'élément de pointe 7,5 m. Longueurs de flèche principale: 66-102 m.
SW:	Flèche principale: idem SH. Fléchette: pied 4,5 m, intercalaires 12 m et 6 m (type 2421) et élément de pointe 7,5 m. Longueurs de flèche principale: 30-66 m. Longueurs de fléchette: 24-84 m.
SSL:	Flèche principale: idem SH. Équipement Superlift, contrepoids Superlift 0-300 t (par progression de 50 t). Longueurs de flèche principale: 36-96 m.
HSSL:	Flèche principale: idem SH/SSL + kit à fortifier de flèche principale. Équipement Superlift, contrepoids Superlift 0-300 t (par progression de 50 t). Longueurs de flèche principale: 54-108 m.
SSL / LSL:	Flèche principale: idem SH 84 m, allongée par type 2421 de la fléchette et par l'élément de pointe 7,5 m. Équipement Superlift, contrepoids Superlift 0-300 t (par progression de 50 t). Longueurs de flèche principale: 90-138 m.
SWSL: (SFSL)	Flèche principale: idem SH. Fléchette: idem SW. Équipement Superlift, contrepoids Superlift 0-300 t (par progression de 50 t). Longueurs de flèche principale: 36-96 m. Longueurs de fléchette: 24-96 m.
HWSL:	Flèche principale: idem HSSL. Fléchette: idem SW/SWSL. Équipement Superlift, contrepoids Superlift 0-300 t (par progression de 50 t). Longueurs de flèche principale: 54-108 m. Longueurs de fléchette: 24-96 m.
LF2:	Flèche principale: idem SH, SSL, HSSL, SH/LH, SH/LH SGLmax; SSL/LSL, SSL/LSL SGLmax. Longueurs de fléchette: 12, 24, 36 m. Inclinaison de fléchette: 10°, 15°, 20° pour longueur de fléchette 12 m. Inclinaison de fléchette: 10°, 20°, 30° pour longueurs de fléchette 24-36 m.
SFVL:	Flèche principale: idem SH, longueurs 42-96 m, sans jeu de poulies. Fléchette: pied 4,5 m, intercalaire 6 m; tête levages-lourds 1,5 m. Jeu de poulies 600 t idem SH.
LFVL:	Flèche principale: idem SH, longueurs 42-96 m, sans jeu de poulies. Fléchette: pied 4,5 m, élément de pointe de fléchette 7,5 m.
SH / LH SGLmax:	Idem SH, allongée de kit à fortifier de flèche principale + élément de pointe de fléchette. Longueurs de flèche principale: 78-102 m.
SSL / LSL SGLmax:	Idem SSL, allongée de kit à fortifier de flèche principale + élément de pointe de fléchette. Longueurs de flèche principale: 90-138 m.
Tambour de mouflage	Monté sur la partie tournante.
Sécurités	Contrôleur d'état de charge électronique, contacteur de fin de course haut, limiteurs de mouvements de la flèche, retenues hydrauliques anti-basculement de la flèche, anémomètre.

EQUIPEMENT OPTIONNEL

Kit à fortifier de flèche principale	Consiste de 2-4 tronçons additionnelles de type flèche principale; flèche principale standard de 84 m nécessaire.
Équipement Superlift standard	Mât 30 m, treuil avec câble et traverse pour 300 t. Radii du mât 11, 13 et 15 m par inclinaison de la position du mât.
Équipement Superlift télescopique	Mât 30 m, treuil avec câble, jonction télescopique et traverse pour 300 t. Position du mât 15 m. Contrepoids Superlift réglable de 13 à 17 m.
Treuil H3	Tambour supplémentaire sur la flèche principale (à utiliser avec LF2 ou runner). Effort au brin simple idem H1, longueur de câble 650 m.
Runner 30 t	Environ 2 m à installer en tête de flèche ou sur l'élément de pointe (pas en combinaison avec LF2).
Runner 60 t	
Boulonnement hydraulique des intercalaires	
W1 en H3	Utilisation de la variation de flèche W1 comme dispositif de levage H3.

NOTES TO LIFTING CAPACITY · ANMERKUNGEN ZU DEN TRAGFÄHIGKEITEN · CONDITIONS D'UTILISATION

Ratings are in compliance with ISO 4305 and DIN 15019.2 (test load = 1.25 x suspended load + 0.1 x dead weight of boom head).
Weight of hook blocks and slings is part of the load, and is to be deducted from the capacity ratings.

Consult operation manual for further details.

Note: Data published herein is intended as a guide only and shall not be construed to warrant applicability for lifting purposes.
Crane operation is subject to the computer charts and operation manual both supplied with the crane.

In some instances the superlift counterweight does not lift off the ground with the indicated load.

Tragfähigkeiten entsprechen ISO 4305 und DIN 15019.2 (Prüflast = 1,25 x Hublast + 0,1 x Kopfgewicht).

Das Gewicht der Unterflaschen, sowie die Lastaufnahmemittel, sind Bestandteile der Last und sind von den Tragfähigkeitsangaben abzuziehen.

Weitere Angaben in der Bedienungsanleitung des Kranes.

Anmerkung: Die Daten dieser Broschüre dienen nur zur allgemeinen Information; für ihre Richtigkeit übernehmen wir keine Haftung.

Der Betrieb des Kranes ist nur mit den Original-Tragfähigkeitstabellen und mit der Bedienungsanleitung zulässig, die mit dem Kran mitgeliefert werden.

In einigen Fällen hebt das Superliftgegengewicht bei den angegebenen Traglasten nicht ab.

Le tableau de charges est conforme à la norme ISO 4305 et DIN 15019.2 (charge d'essai = 1,25 x charge suspendue + 0,1 x poids de la tête de flèche).

Les poids du crochet-moufle et de tous les accessoires d'élingage font partie de la charge et sont à déduire des charges indiquées.

Pour plus de détails consulter la notice d'utilisation de la grue.

Nota: Les renseignements ci-inclus sont donnés à titre indicatif et ne représentent aucune garantie d'utilisation pour les opérations de levage.

La mise en service de la grue n'est autorisée qu'à condition que les tableaux de charges ainsi que le manuel de service, tels que fournis avec la grue, soient observés.

Le contrepoids du superlift ne décolle pas dans certaines configurations des tableaux de charge.

The information contained in this brochure / product catalogue merely consists of general descriptions and a broad compilation of performance features which might not apply precisely as described under specific application conditions or which may change as a result of further product development.

The desired performance features only become binding once expressly agreed in the final contract.

Subject to change without notice!

Die Informationen in dieser Broschüre / diesem Produktkatalog enthalten lediglich allgemeine Beschreibungen bzw. Leistungsmerkmale, die im konkreten Anwendungsfall nicht immer in der beschriebenen Form zutreffen bzw. die sich durch Weiterentwicklung der Produkte ändern können.

Die gewünschten Leistungsmerkmale sind nur dann verbindlich, wenn sie bei Vertragsabschluss ausdrücklich vereinbart werden.

Änderungen vorbehalten!

Les informations figurant dans la présente brochure / le présent catalogue de produit sont de simples descriptions ou des caractéristiques de performances générales qui ne correspondent pas toujours à la forme décrite dans le cas d'applications spécifiques concrètes ou qui peuvent varier en fonction des perfectionnements apportés aux produits.

Seules les caractéristiques de performances expressément convenues à la signature du contrat engagent notre société.

Sous réserve de modification!

09/06